

## TECHNICAL SPECIFICATIONS

# (\*)R4GM Series

## Single Packaged Gas/Electric Units

### (\*)R4GM 9 EER 7½ and 10 Ton Units

The (\*)R4GM is designed specifically for retrofit applications and compatibility with most standard footprints. The (\*)R4GM takes less time to install and retrofit, making the contractor's job more profitable. The (\*)R4GM offers flexibility in the replacement market by utilizing a database of major manufacturer's unit footprints and offers roof curb transitions to meet virtually any configuration.

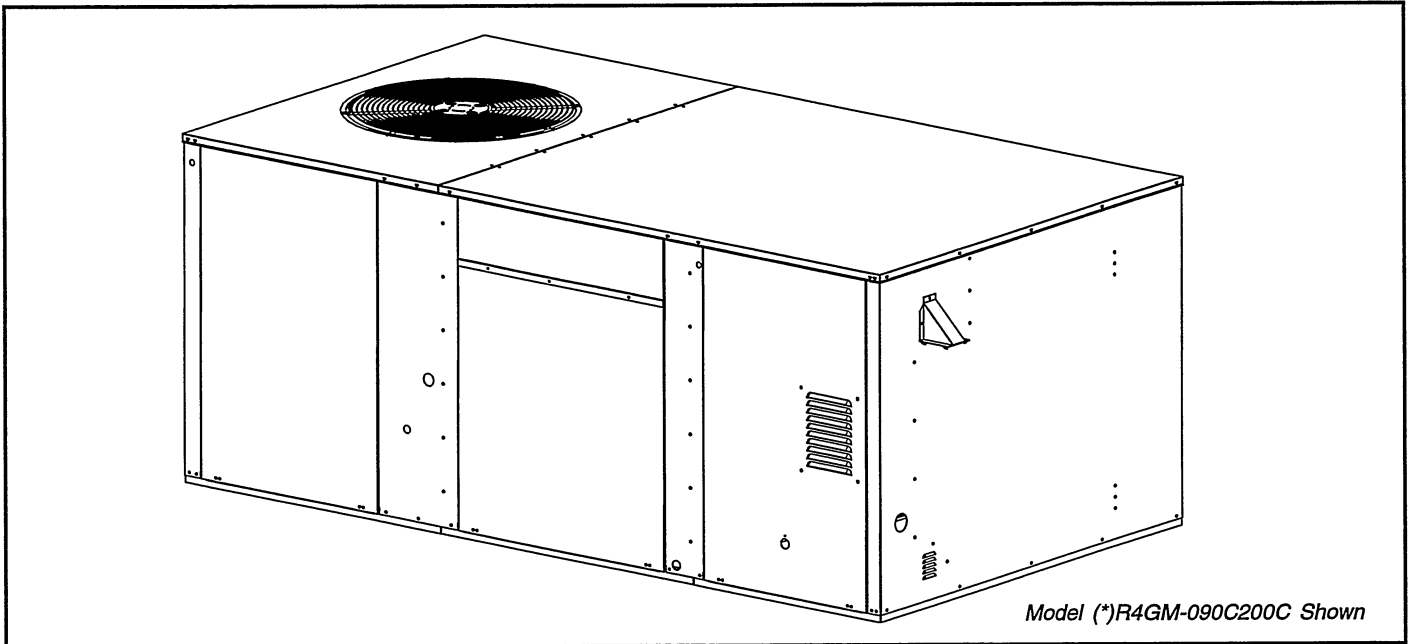

Model (\*)R4GM-090C200C Shown

### FEATURES AND BENEFITS

- **Lifting Lugs**  
Eliminates need for spacer bar and complicated rigging — helps protect the unit during installation.
- **Convertible Air Delivery**  
Fits most standard applications and easily converts to horizontal airflow with kit.
- **Compatibility**  
Fits most standard rooftop applications — can be easily adapted for exceptions.  
Footprint database available for cross-reference.
- **Fully Insulated Bottom Pan**  
Helps ensure quiet operation and prevents condensation.
- **Quick-Release Filter Access Panels** Requires no special servicing tools.
- **20-Gauge Precoated Paint**  
Promotes corrosion resistance and long life.
- **Two-Stage Heating and Cooling**  
Offers heat ranges from 120,000 to 235,000 Btu/h.  
Offers cooling ranges from 45,000/90,000 to 60,000/120,000 Btu/h.  
Dual refrigeration circuits.
- **For Easy Service**  
Hi/low service ports allow quick access without disrupting operation.  
Hi/low pressure switches ensure long compressor life.  
Proven, industry standard components for service and availability.
- **Commercial Warranty**  
1 year limited parts  
5 year compressor  
10 year limited heat exchanger.

Heavy Gauge Lifting Plates

Quick Release Filter Panel

Condenser and Evaporator Coils

Durable Pre-Coat Paint

Condenser Fan Assemblies

Electrical Disconnect Mounting Panel†

High/Low Pressure Switch Protection

Liquid Line Filter Driers

High Efficiency Compressors with Crankcase Heaters

Control Wiring Entry

Power Wiring Entry

Belt Drive Blower Motor

Knockouts for Bottom Power Entry‡

3/4" PVC Condensate Drain

Gas Valve and Burner Assembly

Gas Supply Entry

Aluminized Steel Tubular Heat Exchanger

Inducer Motor

Easy Access Control Panel

†Field Supplied

‡Field Installed Kit Required

Model (\*)R4GM-120C235C Shown

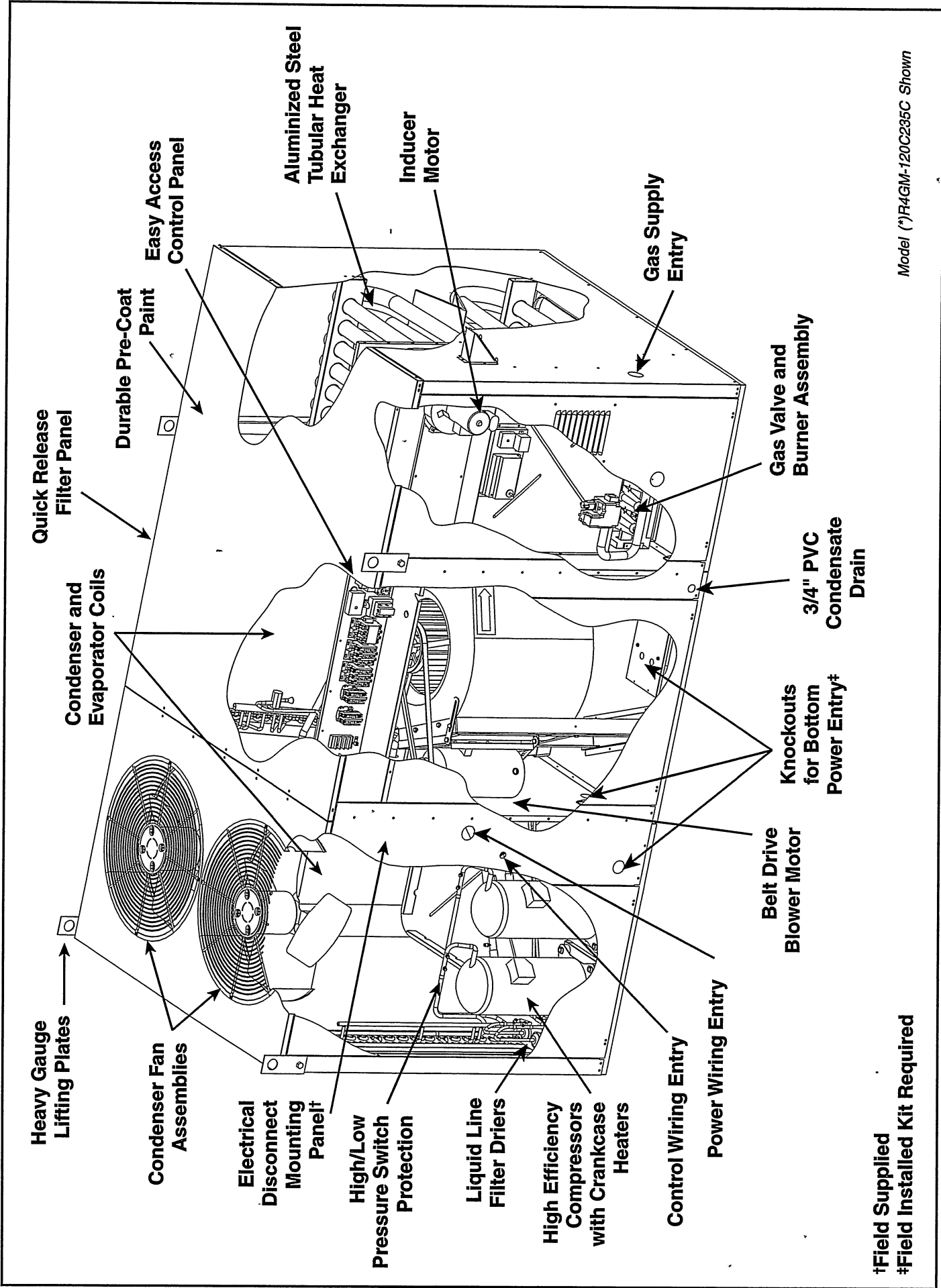

# (\*R4GM-090 SERIES – PHYSICAL DATA

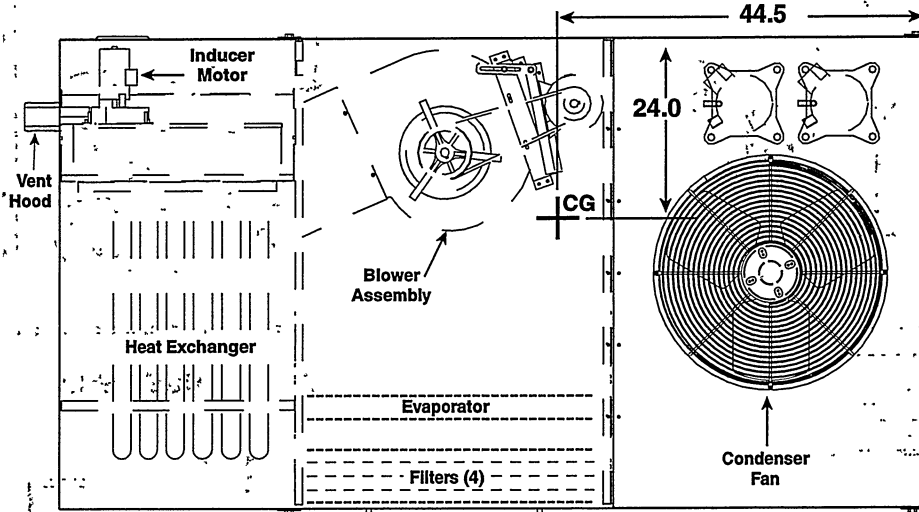

**TOP VIEW**

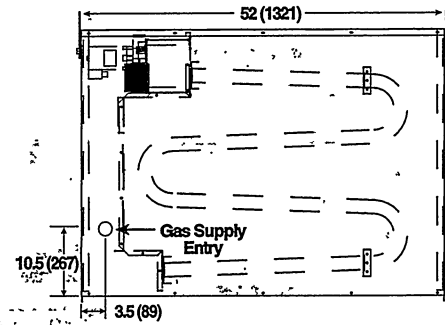

**HEAT EXCHANGER END**

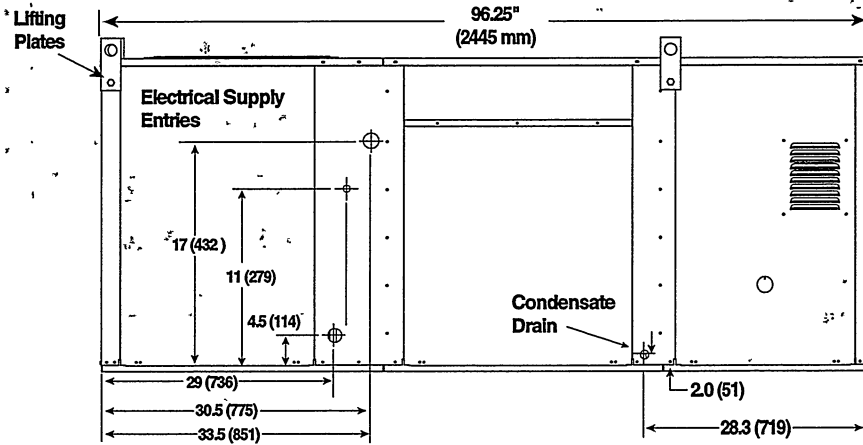

**FRONT VIEW**

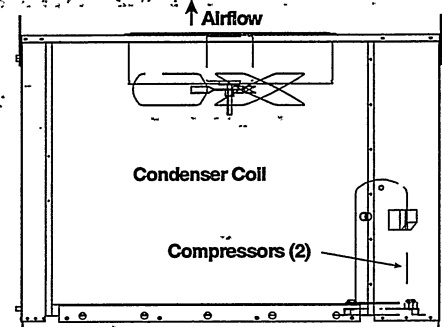

**CONDENSER END**

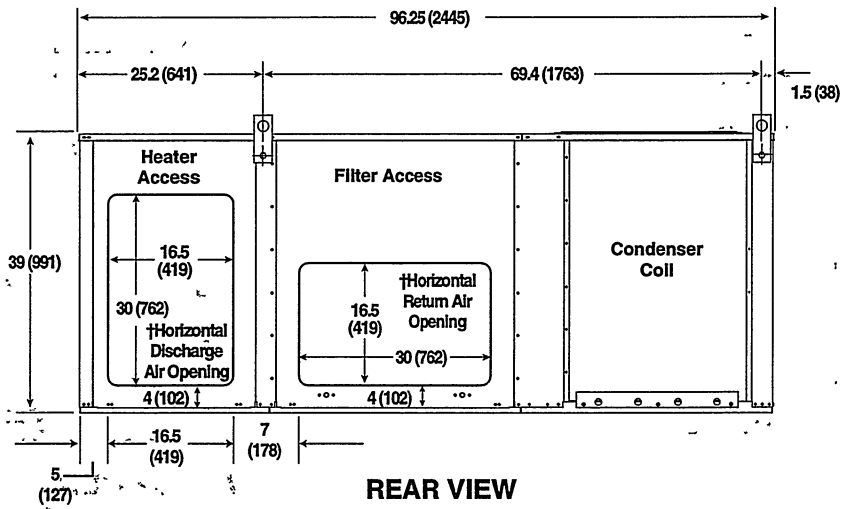

**REAR VIEW**

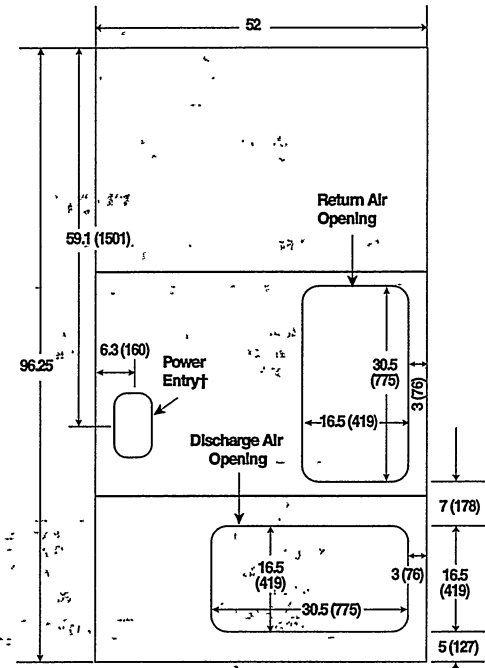

**BOTTOM PAN TOP VIEW**

Model No.	Unit Weight‡		Shipping Weight		Center of Gravity Inches (mm)		Height C Inches (mm)
	Lbs.	Kg.	Lbs.	Kg.	A	B	
(*R4GM-090C200C	863	392	1300	591	44.5 (1130)	24 (610)	39 (991)
(*R4GM-090D200C	863	392	1300	591	44.5 (1130)	24 (610)	39 (991)
(*R4GM-090N200C	863	392	1300	591	44.5 (1130)	24 (610)	39 (991)

‡ Unit weight without packaging or field installed accessories.

† Field installed kit

# (\*R4GM-120 SERIES – PHYSICAL DATA

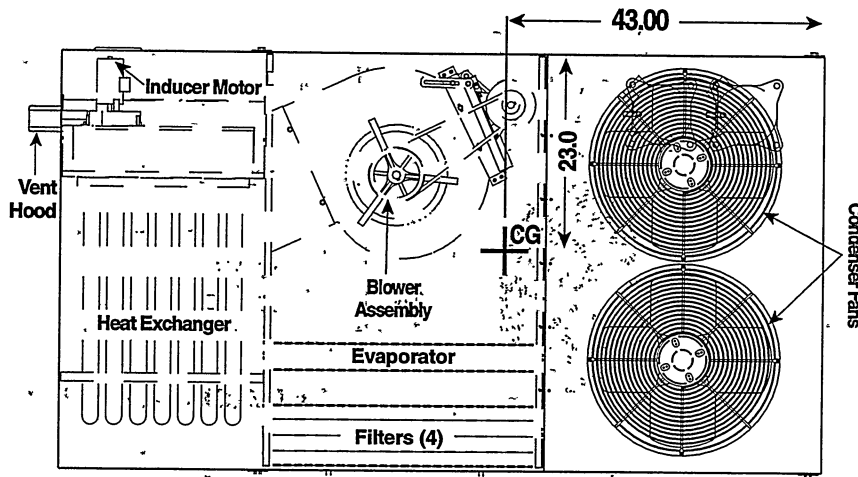

**TOP VIEW**

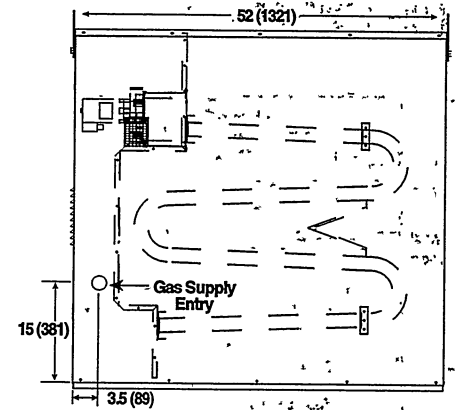

**HEAT EXCHANGER END**

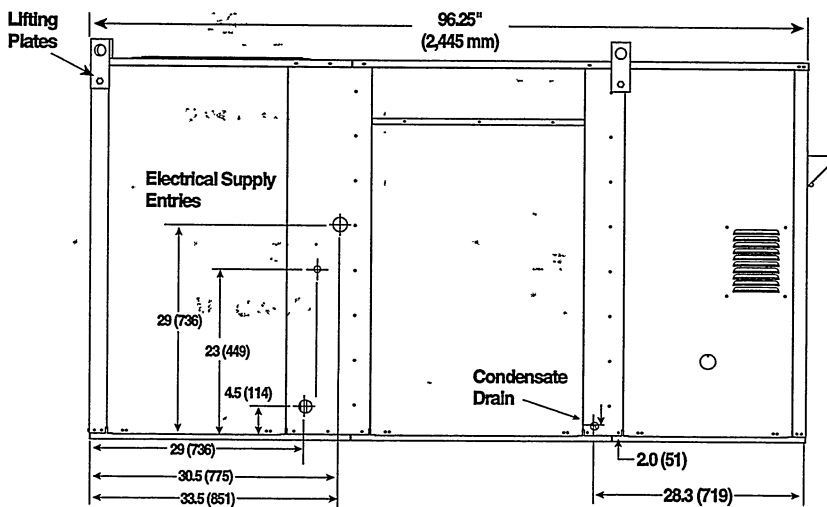

**FRONT VIEW**

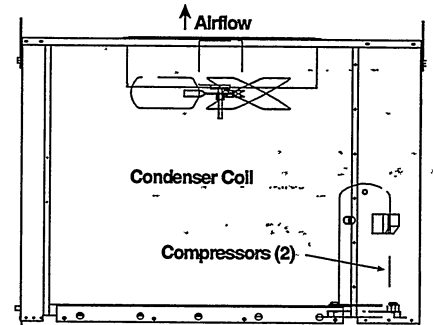

**CONDENSER END**

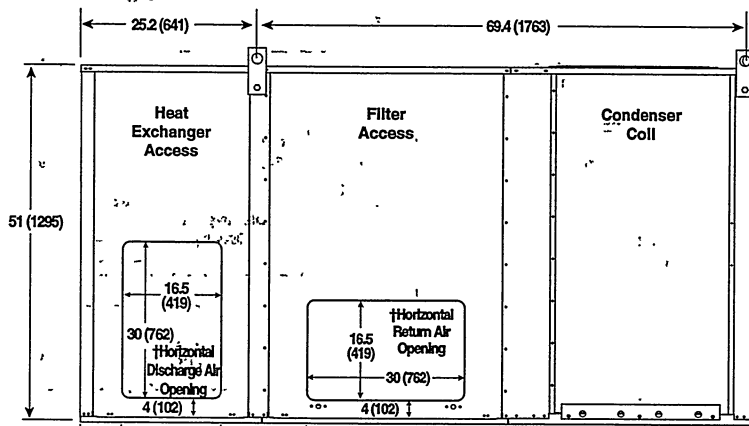

**REAR VIEW**

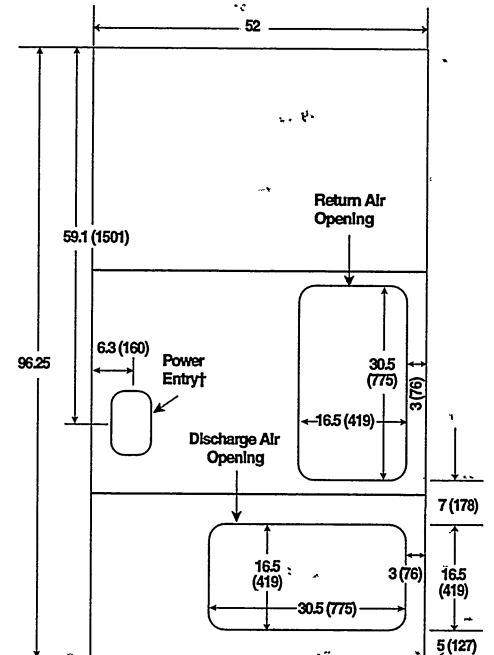

**BOTTOM PAN TOP VIEW**

Model No.	Unit Weight†		Shipping Weight		Center of Gravity Inches (mm)		Height C Inches (mm)
	Lbs.	Kg.	Lbs.	Kg.	A	B	
(*R4GM-120C235C	1210	550	1650	750	43 (1092)	23 (584)	51 (1295)
(*R4GM-120D235C	1210	550	1650	750	43 (1092)	23 (584)	51 (1295)
(*R4GM-120N235C	1210	550	1650	750	43 (1092)	23 (584)	51 (1295)

‡ Unit weight without packaging or field installed accessories.

† Field installed kit

## SPECIFICATIONS AND ELECTRICAL DATA

Model (*)R4GM-	090C200C	090D200C	090N200C	120C235C	120D235C	120N235C
<b>Performance</b>						
Heating Input: BTUH (High)-Nat.	200,000	200,000	200,000	235,000	235,000	235,000
Heating Output BTUH (High)-Nat.	156,000	156,000	156,000	185,000	185,000	185,000
Heating Input: BTUH (Low)-Nat.	120,000	120,000	120,000	150,000	150,000	150,000
Heating Output BTUH (Low)-Nat.	95,000	95,000	95,000	120,000	120,000	120,000
Heating Input: BTUH (High)-L.P.	175,000	175,000	175,000	205,000	205,000	205,000
Heating Output BTUH (High)-L.P.	136,000	136,000	136,000	160,000	160,000	160,000
Heating Input: BTUH (Low)-L.P.	105,000	105,000	105,000	125,000	125,000	125,000
Heating Output BTUH (Low)-L.P.	82,000	82,000	82,000	98,000	98,000	98,000
Capacity-Cooling BTUH (High)	90,000	90,000	90,000	120,000	120,000	120,000
Capacity-Cooling BTUH (Low)	45,000	45,000	45,000	60,000	60,000	60,000
Heating-Steady State Efficiency	78.5%	78.5%	78.5%	78.5%	78.5%	78.5%
Cooling-Efficiency EER	9.00	9.00	9.00	9.00	9.00	9.00
<b>Electrical Rating - 60 Hz.</b>						
Phase	3	3	3	3	3	3
Operating Voltage	187-253	414-506	517-632	187-253	414-506	517-632
Maximum Rated Ampacity	40.8	20.5	16.5	61.1	27.2	22.6
Minimum Circuit Ampacity (MCA)	44.4	22.3	17.9	66.3	29.4	24.5
Max. Overcurrent Protection (MOP)	60	30	25	90	40	35
<b>Compressor Data</b>						
	2 ea.	2 ea.	2 ea.	2 ea.	2 ea.	2 ea.
Volts	208/230	460	575	208/230	460	575
Rated Load Amps	14.3	7.2	5.7	20.7	8.9	7.4
Lock Rotor Amps	91	46	37	128	63	49
<b>Indoor Blower - Belt Drive</b>						
Wheel Diameter	12 x 12	12 x 12	12 x 12	15 x 15	15 x 15	15 x 15
Motor-HP/RPM	2 / 1725	2 / 1725	2 / 1725	3 / 1725	3 / 1725	3 / 1725
Motor Amps	6.3	3.1	2.4	9.1	4.4	3.4
Airflow Range (CFM)	2800 - 3800			3600 - 4600		
<b>Outdoor Fan(s)</b>						
	1 ea.	1 ea.	1 ea.	2 ea.	2 ea.	2 ea.
Motor-HP/RPM	3/4-1060	3/4-1060	3/4-1060	1/2 - 1075	1/2 - 1075	1/2 - 1075
Motor Amps	3.7	1.9	1.7	2.8	1.4	1.2
Fan Diameter/CFM	24" / 5200	24" / 5200	24" / 5200	22" / 8600	22" / 8600	22" / 8600
<b>Refrigerant Charge - oz.</b>						
Stage 1 Circuit	88	88	88	136	136	136
Stage 2 Circuit	88	88	88	136	136	136
High Pressure Switch (PSIG)	425 ± 10 Manual Reset			425 ± 10 Manual Reset		
Loss of Charge Switch (PSIG)	Cut Out: 5 ± 5			Cut Out: 5 ± 5		
	Cut In: 20 ± 5			Cut In: 20 ± 5		
Freeze Protection Thermostat	Opens (°F): 28 ± 5			Opens (°F): 28 ± 5		
	Closes (°F): 57 ± 6			Closes (°F): 57 ± 6		
<b>Filters</b>						
Style	Disposable - 2" Pleated			Disposable - 2" Pleated		
Size (Qty.)	16" x 20" x 2" (4)			16" x 25" x 2" (4)		
Gas Supply Size	3/4"			3/4"		

**(\*R4GM-090(-)C COOLING (With One Compressor Operating)**

CFM	Entering Dry Bulb	Entering Wet Bulb	Outdoor Air Temperature											
			65°F			75°F			85°F			95°F		
			T.C.	S.C.	KW	T.C.	S.C.	KW	T.C.	S.C.	KW	T.C.	S.C.	KW
3000	75	62	41.7	30.7	4.87	40.2	29.9	5.14	38.6	29.1	5.45	36.9	28.2	5.82
	75	67	45.8	26.0	5.04	44.2	25.3	5.31	42.6	24.5	5.64	40.8	23.7	6.01
	75	72	50.6	20.6	5.26	49.2	20.0	5.55	47.5	19.3	5.90	45.7	18.6	6.28
	80	62	41.9	35.5	4.87	40.4	34.7	5.14	38.8	33.8	5.46	37.1	32.9	5.83
	80	67	45.7	31.0	5.03	44.2	30.3	5.31	42.6	29.5	5.64	40.8	28.7	6.02
	80	72	50.2	25.8	5.25	48.7	25.2	5.53	47.0	24.5	5.87	45.1	23.8	6.25
	85	62	42.3	40.0	4.89	40.9	39.2	5.16	39.3	38.2	5.48	37.8	37.1	5.86
	85	67	45.7	35.6	5.03	44.3	34.9	5.31	42.7	34.1	5.64	40.9	33.2	6.02
3375	75	62	43.7	34.6	5.15	42.1	33.7	5.42	40.4	32.9	5.74	38.6	31.9	6.11
	75	67	47.5	28.5	5.32	46.1	27.8	5.61	44.3	27.1	5.94	42.5	26.2	6.31
	75	72	52.5	21.6	5.57	51.0	21.0	5.87	49.2	20.4	6.22	47.3	19.6	6.62
	80	62	44.1	40.5	5.17	42.6	39.6	5.44	41.0	38.6	5.77	39.2	37.5	6.14
	80	67	47.7	34.6	5.33	46.2	33.9	5.61	44.5	33.1	5.94	42.6	32.2	6.32
	80	72	51.8	28.3	5.53	50.3	27.7	5.83	48.5	27.0	6.17	46.6	26.2	6.57
	85	62	45.0	45.0	5.21	43.8	43.8	5.50	42.4	42.4	5.84	40.9	40.9	6.24
	85	67	48.0	40.7	5.34	46.5	40.0	5.63	44.8	39.1	5.96	43.0	38.2	6.34
3750	75	62	45.2	38.1	5.33	43.6	37.3	5.60	41.8	36.3	5.92	39.9	35.3	6.30
	75	67	48.8	31.0	5.50	47.3	30.3	5.79	45.5	29.5	6.12	43.5	28.7	6.50
	75	72	53.7	22.6	5.76	52.2	22.0	6.06	50.4	21.4	6.41	48.1	20.6	6.81
	80	62	45.9	44.3	5.37	44.6	43.3	5.65	42.4	42.4	5.96	40.8	40.8	6.34
	80	67	49.1	38.2	5.52	47.6	37.5	5.80	45.8	36.7	6.13	44.0	35.8	6.52
	80	72	53.1	30.8	5.72	51.5	30.2	6.02	49.7	29.5	6.37	47.8	28.7	6.77
	85	62	47.8	47.8	5.45	46.6	46.6	5.75	45.1	45.1	6.10	43.6	43.6	6.50
	85	67	49.7	45.3	5.55	48.2	44.5	5.84	46.5	43.5	6.17	44.7	42.4	6.56
	85	72	53.4	38.2	5.74	52.0	37.6	6.05	50.2	36.8	6.39	48.0	36.0	6.80

**(\*R4GM-090(-)C COOLING (With Two Compressors Operating)**

CFM	Entering Dry Bulb	Entering Wet Bulb	Outdoor Air Temperature											
			85°F			95°F			105°F			115°F		
			T.C.	S.C.	KW	T.C.	S.C.	KW	T.C.	S.C.	KW	T.C.	S.C.	KW
3000	75	62	64.1	64.8	8.69	80.4	63.0	9.40	76.8	61.2	10.18	73.3	59.4	11.07
	75	67	92.1	54.0	9.00	88.6	52.4	9.73	84.8	50.7	10.57	81.0	49.1	11.50
	75	72	102.0	41.6	9.48	98.3	40.2	10.24	94.3	38.7	11.12	90.3	37.2	12.10
	80	62	84.3	75.5	8.70	80.9	73.6	9.41	77.4	71.6	10.21	74.0	69.7	11.11
	80	67	92.1	65.7	9.00	88.4	64.0	9.72	84.7	62.4	10.57	81.0	59.8	11.49
	80	72	100.7	53.7	9.41	96.9	52.2	10.16	93.0	50.7	11.04	89.0	49.1	12.01
	85	62	85.9	84.2	8.76	82.2	82.1	9.47	79.3	79.3	10.29	76.5	76.5	11.24
	85	67	92.2	75.9	9.00	88.6	74.2	9.73	85.0	72.4	10.58	81.3	70.6	11.51
3375	75	62	85.7	68.4	8.95	81.9	66.5	9.67	78.3	64.7	10.45	74.6	62.8	11.35
	75	67	93.6	56.4	9.27	90.0	54.8	10.01	86.1	53.1	10.86	82.2	51.5	11.79
	75	72	103.6	42.6	9.78	99.7	41.1	10.54	95.7	39.6	11.43	91.6	38.1	12.41
	80	62	86.3	79.9	8.97	82.8	77.8	9.70	79.3	75.6	10.50	75.8	73.3	11.42
	80	67	93.6	68.4	9.27	90.0	66.8	10.00	86.2	65.1	10.86	82.3	63.3	11.79
	80	72	102.2	56.1	9.71	98.4	54.6	10.46	94.4	53.1	11.35	90.4	51.5	12.32
	85	62	88.1	88.1	9.04	85.2	85.2	9.80	82.3	82.3	10.66	79.3	79.3	11.61
	85	67	94.1	80.6	9.29	90.5	78.8	10.03	86.7	76.9	10.88	83.0	75.0	11.83
3750	75	62	102.2	69.3	9.71	98.4	67.8	10.46	94.4	66.1	11.35	90.5	63.4	12.33
	75	67	87.3	71.9	9.12	83.4	70.0	9.83	79.6	68.0	10.65	75.9	66.1	11.54
	75	72	95.1	58.9	9.47	91.3	57.3	10.19	87.4	55.6	11.04	83.4	53.9	11.98
	80	62	105.0	43.6	9.97	101.1	42.2	10.74	96.9	40.7	11.63	92.7	39.1	12.61
	80	67	88.5	84.0	9.17	84.7	81.4	9.89	81.4	78.9	10.73	76.9	76.8	11.60
	80	72	95.4	72.1	9.49	91.5	70.4	10.20	87.6	68.6	11.05	83.6	66.8	11.99
	85	62	103.7	58.6	9.90	99.8	57.1	10.67	95.7	55.5	11.55	91.5	53.9	12.53
	85	67	91.1	91.1	9.28	88.1	88.1	10.03	85.0	85.0	10.92	81.9	81.9	11.89
	85	72	96.0	85.1	9.51	92.2	83.2	10.24	88.4	81.2	11.08	84.6	79.1	12.06
	85	72	103.8	73.3	9.91	100.1	70.3	10.68	96.3	68.8	11.59	92.0	67.1	12.57

T.C.- Total net cooling capacity (mbtuh). S.C.- Sensible cooling capacity (mbtuh).

**(\*)R4GM-0120(-)C COOLING (With One Compressor Operating)**

CFM	Entering Dry Bulb	Entering Wet Bulb	Outdoor Air Temperature											
			65°F			75°F			85°F			95°F		
			T.C.	S.C.	kW	T.C.	S.C.	kW	T.C.	S.C.	kW	T.C.	S.C.	kW
3750	75	62	55.1	40.3	6.34	53.2	39.4	6.66	51.2	38.3	7.04	48.8	36.8	7.47
	75	67	60.7	33.9	6.56	59.0	33.2	6.85	56.9	32.2	7.21	54.6	31.2	7.63
	75	72	66.6	27.1	6.82	65.1	26.4	7.10	63.1	25.6	7.45	60.7	24.6	7.86
	80	62	54.9	46.1	6.34	53.2	45.2	6.66	51.2	44.1	7.04	49.0	42.8	7.47
	80	67	60.4	40.4	6.55	58.8	39.6	6.84	56.8	38.6	7.20	54.3	37.5	7.63
	80	72	66.4	33.7	6.80	64.8	33.1	7.09	62.8	32.2	7.43	60.4	31.3	7.85
	85	62	55.3	51.9	6.35	53.6	51.0	6.67	51.7	49.8	7.05	49.6	48.4	7.49
	85	67	60.3	46.3	6.54	58.6	45.5	6.84	56.6	44.4	7.20	54.3	43.3	7.62
4250	85	72	66.0	40.2	6.79	64.3	39.5	7.07	62.4	38.7	7.42	60.1	37.7	7.83
	75	62	58.2	45.8	6.66	56.5	44.9	6.96	54.3	43.8	7.32	51.8	42.5	7.75
	75	67	63.6	37.8	6.89	61.9	37.1	7.17	59.8	36.1	7.52	57.3	35.0	7.93
	75	72	69.9	28.7	7.17	68.3	28.0	7.46	66.1	27.2	7.80	63.7	26.3	8.20
	80	62	58.7	53.6	6.68	56.9	52.6	6.98	54.8	51.4	7.34	52.5	50.0	7.77
	80	67	63.8	45.8	6.90	62.0	45.1	7.18	59.9	44.1	7.52	57.5	43.0	7.94
	80	72	69.4	37.5	7.15	67.6	36.9	7.43	65.4	36.0	7.76	63.0	35.0	8.17
	85	62	59.7	59.7	6.72	58.4	58.4	7.03	56.6	56.6	7.40	54.7	54.7	7.84
4750	85	67	63.7	53.8	6.89	62.2	53.0	7.18	60.1	52.0	7.53	57.7	50.8	7.94
	85	72	69.4	46.1	7.15	67.6	45.4	7.43	65.5	44.0	7.77	63.1	43.0	8.17
	75	62	60.5	51.0	6.87	58.9	50.2	7.16	56.5	49.0	7.51	54.0	47.7	7.92
	75	67	65.7	41.4	7.10	63.9	40.7	7.38	61.8	39.7	7.71	59.2	38.6	8.12
	75	72	71.9	30.1	7.38	70.2	29.5	7.67	68.0	28.7	8.01	65.5	27.8	8.41
	80	62	61.5	59.6	6.92	59.9	58.4	7.20	57.3	57.2	7.54	55.2	55.2	7.97
	80	67	66.0	51.1	7.11	64.2	50.4	7.39	62.1	49.4	7.72	59.6	48.2	8.13
	80	72	71.3	41.1	7.35	69.5	40.4	7.64	67.4	39.6	7.97	64.8	38.6	8.38
4750	85	62	64.0	64.0	7.02	62.7	62.7	7.32	60.9	60.9	7.67	58.8	58.8	8.10
	85	67	66.5	60.6	7.13	64.8	59.7	7.41	62.7	58.6	7.75	60.3	57.2	8.16
	85	72	71.6	51.0	7.37	69.8	50.2	7.65	67.6	49.3	7.99	65.1	48.3	8.39

**(\*)R4GM-0120(-)C COOLING (With Two Compressors Operating)**

CFM	Entering Dry Bulb	Entering Wet Bulb	Outdoor Air Temperature											
			85°F			95°F			105°F			115°F		
			T.C.	S.C.	kW	T.C.	S.C.	kW	T.C.	S.C.	kW	T.C.	S.C.	kW
3750	75	62	111.8	89.0	11.84	106.6	86.4	12.69	101.8	84.0	13.68	96.9	81.6	14.83
	75	67	123.2	73.3	12.21	117.9	71.0	13.06	112.4	68.7	14.03	107.1	66.4	15.22
	75	72	135.7	55.6	12.71	130.5	53.5	13.55	124.8	51.4	14.56	119.2	49.3	15.74
	80	62	112.6	104.4	11.86	107.6	101.7	12.72	102.9	99.0	13.72	98.4	96.2	14.90
	80	67	123.0	89.2	12.20	117.7	86.8	13.05	112.3	84.4	14.03	107.0	82.1	15.21
	80	72	135.0	72.9	12.68	129.6	70.8	13.52	123.9	68.7	14.51	118.1	66.5	15.70
	85	62	115.7	115.7	11.96	111.6	111.6	12.85	107.5	107.5	13.87	103.5	103.5	15.08
	85	67	123.4	105.0	12.22	118.2	102.6	13.07	112.9	100.1	14.05	107.8	97.7	15.22
4250	85	72	134.9	89.7	12.67	129.5	86.8	13.51	123.9	84.6	14.52	118.3	82.4	15.74
	75	62	114.3	94.7	12.11	108.9	92.1	12.96	103.6	89.5	13.94	98.6	86.9	15.11
	75	67	125.5	77.2	12.50	120.1	74.9	13.34	114.4	72.5	14.33	108.9	70.2	15.48
	75	72	137.9	57.1	13.03	132.6	55.1	13.86	126.8	53.0	14.86	121.0	50.9	16.04
	80	62	115.7	111.3	12.16	110.7	108.1	13.02	105.3	105.1	14.02	101.0	101.0	15.21
	80	67	125.2	94.8	12.49	120.0	92.5	13.34	114.5	90.1	14.33	109.0	87.7	15.48
	80	72	137.0	76.7	12.98	131.7	74.6	13.82	125.8	72.4	14.82	120.0	70.2	16.00
	85	62	120.7	120.7	12.32	116.4	116.4	13.21	112.1	112.1	14.22	107.8	107.8	15.43
4750	85	67	126.3	112.6	12.53	121.0	110.0	13.37	115.6	107.3	14.38	110.4	104.6	15.54
	85	72	137.3	94.6	12.99	131.9	92.5	13.83	126.2	90.3	14.83	120.4	88.0	16.02
	75	62	116.5	100.3	12.29	111.0	97.6	13.14	105.6	94.8	14.12	100.5	92.1	15.30
	75	67	127.5	81.0	12.69	122.0	78.7	13.52	116.2	76.3	14.52	110.5	74.0	15.66
	75	72	139.9	58.7	13.23	134.4	56.7	14.06	128.6	54.5	15.06	122.6	52.4	16.24
	80	62	117.7	117.5	12.36	113.4	113.4	13.21	108.9	108.9	14.23	104.5	104.5	15.43
	80	67	127.5	100.5	12.69	122.2	98.2	13.53	116.5	95.7	14.52	110.9	93.2	15.68
	80	72	139.0	80.5	13.19	133.5	78.4	14.02	127.6	76.2	15.02	121.8	74.0	16.20
4750	85	62	125.1	125.1	12.60	120.7	120.7	13.48	116.2	116.2	14.51	111.7	111.7	15.71
	85	67	129.0	119.6	12.75	123.7	116.8	13.59	118.3	113.8	14.60	113.1	110.4	15.78
	85	72	139.2	100.3	13.21	134.0	98.2	14.04	128.1	95.9	15.04	122.3	93.6	16.22

T.C.- Total net cooling capacity (mbtuh). S.C.- Sensible cooling capacity (mbtuh).

## (\*)R4GM-090\*-200C Series Fan Performance

### Vertical Discharge

Air Volume (CFM)	External Static Pressure (Inches Water Column)							
	0.2	0.4	0.5	0.6	0.7	0.8	0.9	1.0
	BHP RPM (KW)	BHP RPM (KW)	BHP RPM (KW)	BHP RPM (KW)	BHP RPM (KW)	BHP RPM (KW)	BHP RPM (KW)	BHP RPM (KW)
2600			<b>788</b>	<b>812</b>	<b>842</b>	<b>895</b>	<b>944</b>	<b>988</b>
			0.91	0.95	1.00	1.08	1.17	1.26
2800		<b>756</b>	<b>816</b>	<b>845</b>	<b>875</b>	<b>912</b>	<b>950</b>	<b>991</b>
		0.94	1.02	1.06	1.10	1.18	1.27	1.34
3000	<b>730</b>	<b>785</b>	<b>840</b>	<b>865</b>	<b>895</b>	<b>945</b>	<b>989</b>	
	1.07	1.18	1.29	1.34	1.38	1.49	1.58	
	0.97	1.07	1.17	1.22	1.26	1.36	1.44	
3200	<b>752</b>	<b>810</b>	<b>868</b>	<b>900</b>	<b>924</b>	<b>980</b>	<b>1030</b>	
	1.17	1.31	1.44	1.49	1.56	1.68	1.77	
	1.06	1.19	1.31	1.36	1.42	1.53	1.61	
3400	<b>808</b>	<b>864</b>	<b>910</b>	<b>932</b>	<b>955</b>	<b>1010</b>		
	1.40	1.51	1.63	1.68	1.74	1.86		
	1.27	1.37	1.48	1.53	1.58	1.69		
3600	<b>863</b>	<b>910</b>	<b>942</b>	<b>965</b>	<b>982</b>			
	1.63	1.71	1.80	1.86	1.90			
	1.48	1.56	1.64	1.69	1.73			

### Horizontal Discharge

Air Volume (CFM)	External Static Pressure (Inches Water Column)							
	0.2	0.4	0.5	0.6	0.7	0.8	0.9	1.0
	BHP RPM (KW)	BHP RPM (KW)	BHP RPM (KW)	BHP RPM (KW)	BHP RPM (KW)	BHP RPM (KW)	BHP RPM (KW)	BHP RPM (KW)
2600			<b>758</b>	<b>785</b>	<b>815</b>	<b>850</b>	<b>905</b>	<b>940</b>
			0.96	0.99	1.01	1.03	1.06	1.10
			0.87	0.90	0.92	0.94	0.96	1.00
2800		<b>725</b>	<b>780</b>	<b>810</b>	<b>840</b>	<b>880</b>	<b>920</b>	<b>955</b>
		0.99	1.03	1.06	1.07	1.12	1.21	1.25
		0.90	0.94	0.96	0.97	1.02	1.10	1.14
3000	<b>700</b>	<b>755</b>	<b>805</b>	<b>830</b>	<b>860</b>	<b>905</b>	<b>940</b>	<b>970</b>
	1.01	1.07	1.10	1.12	1.19	1.29	1.37	1.46
	0.92	0.97	1.00	1.02	1.08	1.17	1.25	1.33
3200	<b>720</b>	<b>780</b>	<b>830</b>	<b>865</b>	<b>895</b>	<b>925</b>	<b>955</b>	<b>987</b>
	1.10	1.12	1.21	1.25	1.35	1.49	1.58	1.65
	1.00	1.02	1.10	1.14	1.23	1.36	1.44	1.5
3400	<b>752</b>	<b>820</b>	<b>855</b>	<b>880</b>	<b>910</b>	<b>950</b>	<b>985</b>	
	1.26	1.34	1.42	1.52	1.62	1.70	1.78	
	1.15	1.22	1.29	1.38	1.47	1.55	1.62	
3600	<b>810</b>	<b>875</b>	<b>905</b>	<b>935</b>	<b>960</b>	<b>982</b>		
	1.43	1.56	1.65	1.74	1.82	1.93		
	1.30	1.42	1.50	1.58	1.66	1.76		

**Notes:**

1. BHP - Brake Horsepower Input to Fan
2. Boldface indicates factory recommended blower operating range.
3. Values include losses for air filters, unit casing, and dry evaporator coil.  
See Accessory Performance Data table for additional static pressure information.



## (\*)R4GM-120\*-235C Series Fan Performance

### Vertical Discharge

Air Volume (CFM)	External Static Pressure (Inches Water Column)													
	0.2	0.4	0.5	0.6	0.7	0.8	0.9	1.0						
	BHP RPM (KW)	BHP RPM (KW)	BHP RPM (KW)	BHP RPM (KW)	BHP RPM (KW)	BHP RPM (KW)	BHP RPM (KW)	BHP RPM (KW)						
3600				752	1.56	780	1.63	810	1.69	835	1.76			
					1.42		1.48		1.54		1.60			
3800			751	1.63	778	1.69	805	1.78	830	1.89	855	1.99		
				1.48		1.54		1.62		1.72		1.81		
4000		749	1.76	777	1.80	805	1.88	829	1.93	854	2.07	879	2.21	
			1.60		1.64		1.71		1.76		1.88		2.01	
4200	720	1.71	773	1.92	800	1.98	827	2.04	850	2.18	875	2.32	900	2.41
		1.56		1.75		1.80		1.86		1.98		2.11		2.19
4400	745	1.87	798	2.08	825	2.17	850	2.31	874	2.45	900	2.53	924	2.63
		1.70		1.89		1.97		2.10		2.23		2.30		2.39
4600	767	2.03	824	2.23	848	2.42	872	2.57	898	2.66	923	2.75	950	2.86
		1.85		2.03		2.20		2.34		2.42		2.50		2.60
4800	790	2.23	846	2.53	870	2.68	896	2.79	922	2.89	950	2.99		
		2.03		2.30		2.44		2.54		2.63		2.72		

### Horizontal Discharge

Air Volume (CFM)	External Static Pressure (Inches Water Column)													
	0.2	0.4	0.5	0.6	0.7	0.8	0.9	1.0						
	BHP RPM (KW)	BHP RPM (KW)	BHP RPM (KW)	BHP RPM (KW)	BHP RPM (KW)	BHP RPM (KW)	BHP RPM (KW)	BHP RPM (KW)						
3600				735	1.48	760	1.59	783	1.67	805	1.76			
					1.35		1.45		1.52		1.60			
3800			740	1.54	759	1.65	782	1.75	805	1.82	830	1.91		
				1.40		1.50		1.59		1.66		1.74		
4000			760	1.73	781	1.81	805	1.89	829	1.96	854	2.09		
				1.57		1.65		1.72		1.78		1.90		
4200		758	1.81	779	1.89	803	1.98	827	2.07	850	2.20	877	2.34	
			1.65		1.72		1.80		1.88		2.00		2.13	
4400		776	1.99	800	2.07	825	2.13	850	2.30	876	2.46	900	2.54	
			1.81		1.88		1.94		2.09		2.24		2.31	
4600	774	2.10	799	2.17	823	2.23	848	2.37	874	2.52	898	2.65	921	2.75
		1.91		1.97		2.03		2.16		2.29		2.41		2.50
4800	773	2.18	822	2.34	850	2.50	872	2.65	895	2.77	919	2.88		
		1.98		2.13		2.27		2.41		2.52		2.62		

**Notes:**

1. BHP - Brake Horsepower Input to Fan
2. Boldface indicates factory recommended blower operating range.
3. Values include losses for air filters, unit casing, and dry evaporator coil.  
See Accessory Performance Data table for additional static pressure information.

## Accessory Performance Data

Model No.	Air Volume (CFM)	Total Resistance (inches water column)									
		Wet Evaporator Coil	Downflow Economizer	Horizontal Economizer	Step Down Diffuser System				Flush Mount Diffuser System	Throw Feet	
					2 Ends Open	2 Ends Open w/1 Side Open	2 Ends Open w/2 Sides Open	2 Ends Open w/2 Sides Open			
(*)R4GM-090	2600	0.12	0.30	0.04	0.20	0.20	0.15	0.17	24-29	19-24	
	2800	0.14	0.35	0.04	0.25	0.25	0.20	0.20	25-30	20-28	
	3000	0.16	0.40	0.04	0.30	0.30	0.25	0.25	27-33	21-29	
	3200	0.18	0.45	0.05	0.40	0.38	0.30	0.31	28-35	22-29	
	3400	<b>0.20</b>	<b>0.50</b>	<b>0.05</b>	<b>0.50</b>	<b>0.46</b>	<b>0.40</b>	<b>0.37</b>	<b>30-37</b>	<b>22-30</b>	
	3600	0.22	0.55	0.05	0.60	0.55	0.50	0.43	32-39	23-31	

Model No.	Air Volume (CFM)	Total Resistance (inches water column)									
		Wet Evaporator Coil	Down Flow Economizer	Horizontal Economizer	Step Down Diffuser System				Flush Mount Diffuser System	Throw Feet	
					2 Ends Open	2 Ends Open w/1 Side Open	2 Ends Open w/2 Sides Open	2 Ends Open w/2 Sides Open			
(*)R4GM-120	3600	0.12	0.20	0.04	0.35	0.25	0.20	0.17	25-33	22-29	
	3800	0.13	0.22	0.04	0.40	0.30	0.25	0.18	27-35	22-30	
	4000	0.14	0.24	0.04	0.45	0.35	0.30	0.21	29-37	24-33	
	4200	<b>0.16</b>	<b>0.27</b>	<b>0.05</b>	<b>0.50</b>	<b>0.40</b>	<b>0.35</b>	<b>0.24</b>	<b>32-40</b>	<b>26-35</b>	
	4400	0.18	0.30	0.05	0.55	0.45	0.40	0.27	34-42	28-37	
	4600	0.20	0.33	0.05	0.60	0.50	0.45	0.30	36-44	30-39	

**Bold italicized numbers indicate factory blower setting.**

# ACCESSORIES

Nordyne Part #	Description	(*)R4GM	(*)R4GM
		-090	-120
		X	X
547860	Hinged Roof Curb 8" High - K/D	X	X
547861	Hinged Roof Curb 14" High - K/D	X	X
547862	Hinged Roof Curb 18" High - K/D	X	X
547863	Hinged Roof Curb 24" High - K/D	X	
547864	0-35% Manual Outside Air Damper	X	X
547865	0-35% Motorized Damper - Only	X	
547866	Economizer - Modulating w/ Relief, Adapts Horizontal	X	
547883	Economizer - 3 Position w/ Relief, Adapts Horizontal		X
547884	Economizer - 3 Position w/ Relief, Adapts Horizontal		X
547875	Economizer - Modulating w/ Relief, Adapts Horizontal	X	
547867	Power Exhaust - Prop (208/230v/3ph), Adapts Horizontal	X	
547868	Power Exhaust - Prop (460v/3ph), Adapts Horizontal	X	
547890	Power Exhaust - Prop (575v/3ph), Adapts Horizontal	X	
547869	20" Supply & Return Transition Round	X	
547870	20" Flush Mount Concentric Diffuser Round	X	
547871	20" Step Down Concentric Diffuser Round	X	
547872	Horizontal Supply & Return Kit	X	
547873	Hooded Hail Guard	X	X
547848	CO2 Sensor - 4-9v dc		X
547874	0-35% Manual Outside Air Damper		X
547876	Power Exhaust - Prop (208/230v/3ph), Adapts Horizontal		X
547877	Power Exhaust - Prop (460v/3ph), Adapts Horizontal		X
547891	Power Exhaust - Prop (575v/3ph), Adapts Horizontal		X
547878	18" x 28" Supply & Return Transition		X
547879	18" x 28" Flush Mount Concentric Diffuser		X
547880	18" x 28" Step Down Concentric Diffuser		X
547881	Horizontal Supply & Return Kit		X
547882	Hooded Hail Guard		X
917159	Thermostat-2 stage Heat/Cool	X	X
917163	Low Ambient Kit	X	X
917164	LP Conversion Kit	X	X
917165	Bottom Power Entry Kit	X	X



St. Louis, MO

**NORDYNE**

706A-1200 (Replaces 706A-0800)

Before purchasing this appliance, read important energy cost and efficiency information available from your retailer. Specifications and illustrations subject to change without notice and without incurring obligations. Printed in U.S.A.