

# **INSTALLATION & OPERATING INSTRUCTIONS**

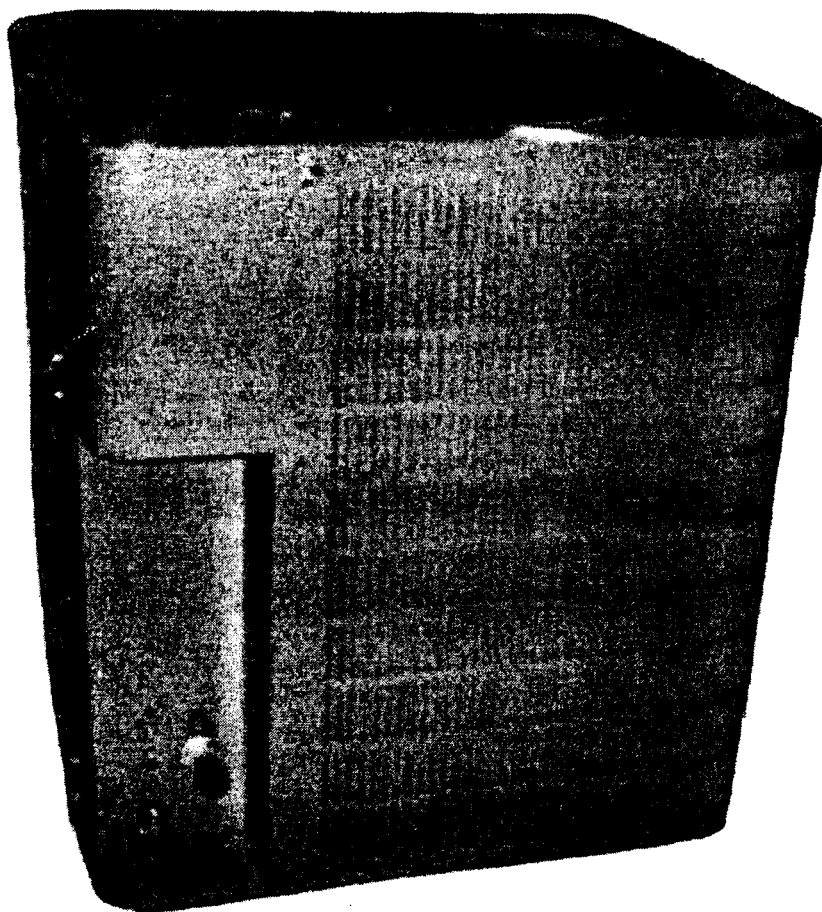

## **7-1/2 & 10 TON AIR COOLED CONDENSING UNIT**

IO-226A

GOODMAN MANUFACTURING COMPANY, L.P.  
2550 North Loop West, Suite 400  
Houston, Texas 77092

4/02

## I General Warnings

### WARNING

Before servicing or installing this equipment, the electrical power to this unit **must** be in the "OFF" position. Caution, more than one disconnect may exist. Failure to observe this warning may result in an electrical shock that can cause personal injury.

### WARNING

The unit **must** have an uninterrupted, unbroken electrical ground to minimize the possibility of personal injury if an electrical fault should occur. The electrical ground circuit may consist of an appropriately sized electrical wire connecting the ground lug in the unit control box wire to the building electrical service panel. Other methods of grounding are permitted if performed in accordance with the "National Electric Code" (NEC)/"American National Standards Institute" (ANSI)/"National Fire Protection Association" (NFPA) 70 and local/state codes. In Canada, electrical grounding is to be in accordance with the Canadian Electric Code CSA C22.1. Failure to observe this warning can result in electrical shock that can cause personal injury.

Due to high system pressure and electrical shock potential, installing and the servicing air conditioning systems can be hazardous. **ONLY TRAINED AND QUALIFIED PERSONNEL ARE PERMITTED TO INSTALL OR SERVICE THIS EQUIPMENT.** Observe ALL warnings contained in this manual and labels/tags attached to the equipment.

When installing or servicing this equipment safety clothing including hand and eye protection is strongly advised. If installing this equipment in an area that has special safety requirements (hard hats etc.) observe these requirements. To protect the unit when welding close to the painted surfaces the use of a quenching cloth is strongly advised to prevent scorching or marring of the equipment finish.

Read these instructions before performing this installation or servicing this unit. All installations must be in accordance with all national, state, or local building codes.

## II Model Identification

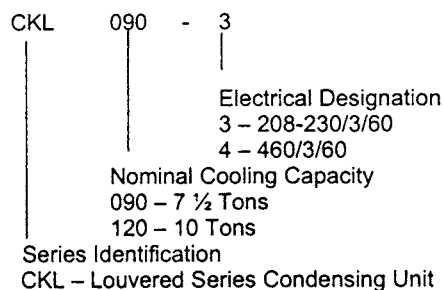

## III Product Description

When matched with the appropriate airhandler(s) or evaporator coil(s) the CKL090/120 condenser complies with the minimum efficiency requirements found in ASHRAE 90.1-1999. See the Goodman

CKL90/120 specification sheet for the indoor model selection recommendation.

The CKL series are intended for use with a single stage room thermostat. This thermostat is not supplied with this equipment. Only thermostats that use 24 VAC control circuitry are to be used.

	CKL090	CKL120
Net Weight (Lbs.)	345	395
Shipping Weight (Lbs.)	370	420
Refrigerant	R22	
Compressor Type	Scroll	
Quantity	1	
Oil Charge Initial/Recharge	85/81	110/106
Condenser Fan Type	Propeller	
Fan Diameter (in)	26	
Fan Motor Type	Direct Drive PSC	
Fan Motor (HP)	1	
Fan Motor (RPM)	1100	
Nominal Cond. Airflow (CFM)	6600	
Condenser Coil Material	Rifflted Copper Tubes / Al Fins	
Face Area (Ft <sup>2</sup> )	30	
Refrigerant Connections	Sweat Type	
Suction Line Connection (in)	1 3/8	
Liquid Line Connection(in)	5/8	
High Pressure Control (PSIG)	425 Cut-out / Manual Reset	
Low Pressure Control (PSIG)	7 Cut-out / 25 Cut-in	

## IV Ductwork Considerations

To ensure correct performance the indoor ductwork is to be sized to accommodate 375-425 CFM per ton of cooling with the static pressure not to exceed .5" WC. Inadequate ductwork that restricts airflow can result in improper cooling performance and compressor failure.

## V Unit Inspection

Upon delivery, the unit is to be inspected for damage. Any damage must be reported immediately to the carrier. Do not install this equipment if it is determined that the integrity or safety has been compromised by freight damage.

Using the "Model Identification" section, check the equipment model number to ensure the following:

- Correct Size and Model
- Correct Voltage

If an incorrect unit is supplied it must not be installed and it is to be returned to the supplier. The manufacturer assumes no responsibility for the installation of incorrect delivered units.

## VI Site Selection

This unit is designed for outdoor installations only.

Air Supply. The CKL series are air-cooled condensers. To ensure the optimum unit performance the installation site should provide unobstructed airflow. See the following sketch for

minimum clearances from other air-cooled condensers and obstructions such as walls or overhangs. Note: It is recommended that adequate service clearances also be considered.

section of this manual.

**Slab Mounting.** The slab **must** be capable of supporting the weight of the unit. The slab should be a minimum of 6" wider than the unit in all directions. If required the slab should be elevated to protect the unit from water damage due to flooding. Before installing the unit onto a slab, the wooden shipping skid **must** be removed.

**Roof Mounting.** Give careful consideration to the load carrying capability of the roof. If possible locate the unit where walls or partitions can offer additional support. If doubt exists regarding the integrity of the roof or its supporting structure consult a structural engineer.

### VIII Rigging

#### WARNING

All panels **must** be in position and secured before lifting this equipment.

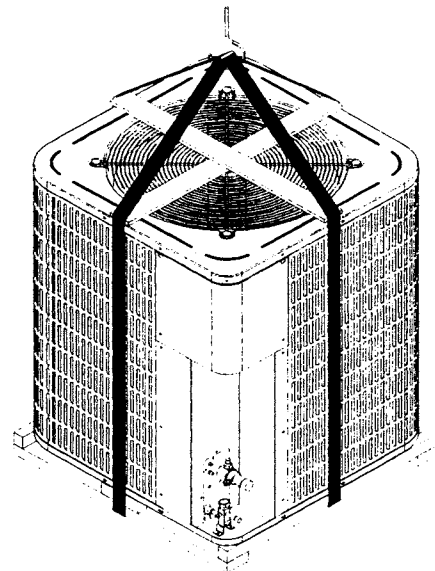

When lifting the unit use spreader bars (field supplied). This practice will minimize the possibility of lifting cable/straps damage. Also, to protect the cabinet louvers, the use of protective material such as plywood behind the cables/straps is recommended. Arrange the straps to form a central suspension point (see the previous sketch for details). When raising and setting the unit observe all safety rules. When the unit is in position the wooden shipping skid, all protection and lifting materials are to be removed.

### IX Unit Corner Weight

The following table and sketch is to be used for determining the unit corner weight. The unit net weight and shipping weight is provided in the "Product Description" section of this manual.

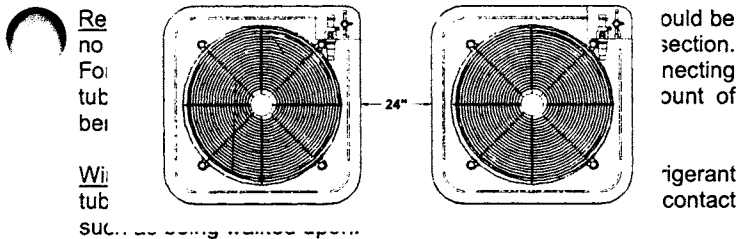
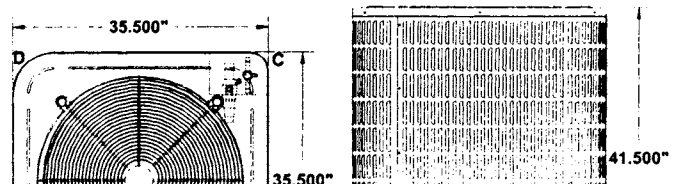

**Vibration and Sound Control.** The CKL series is engineered to produce the minimum sound and vibration. To minimize the possibility of either sound or vibration issues the CKL condenser is to be securely mounted to a surface that is:

- Solid
- Greatest practical mass
- Ridged
- Minimum radiating surface

When possible the slab for a ground level unit should not be connected to the wall or the building.

**Prohibited Locations.** Do not locate this unit in the following locations:

- Inside a building
- Directly under a vent termination from a gas appliance
- Within 3 feet of a clothes drier vent
- Where water may rise into the unit

### VII Typical Installations

The typical locations for the CKL unit is slab mounted and roof mounted. For unit weight data see the "Product Description"

Corner	CKL090	CKL120
A	90 Lbs.	105 Lbs.
B	90 Lbs.	105 Lbs.
C	75 Lbs.	80 Lbs.
D	90 Lbs.	105 Lbs.

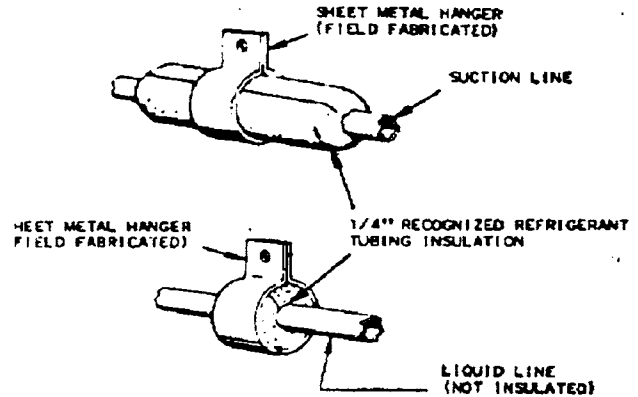

## X Refrigerant Tubing

### WARNING

To avoid overheating of the service valves protect the valve with a wet rag or similar approved thermal heat trap.

As previously noted protective clothing and eye protection should be used when making any welded connection.

Preparing the Tubing. All cut ends are to be round, burr free, and cleaned. Failure to follow this practice increases the chances for refrigerant leaks.

Post Brazing. Quench all welded joints with water or a wet rag.

Piping Size Using a carefully estimated length of refrigerant tubing (distance between condenser and evaporator). Apply the following table to determine the tubing diameter:

Model	0' - 24'		*25' - 49'		50' - 74'		75' - 99'	
	Outside Diameter Line Size (in)							
	L	S	L	S	L	S	L	S
CK	5/8	1 1/8	5/8	1 3/8	5/8	1 3/8	5/8	1 3/8
CKL120	5/8	1 3/8	5/8	1 5/8	5/8	1 5/8	5/8	1 5/8

L = Liquid Line S = Suction Line \* = Full Rating Line Size

Suction Line Insulation. All suction lines are to be insulated with a recognized tubing insulation that is a minimum of 3/8" thick.

Hangers and Isolation. All refrigerant lines are to be isolated from the structure and supported with hangers. See the following sketch for details.

Inverted Suction Line Loop. When the condenser is located at the same level or above the evaporator section, an inverted loop is to be employed on the suction line. This practice will prevent liquid refrigerant from migrating into the compressor during shutdown. See the following sketch.

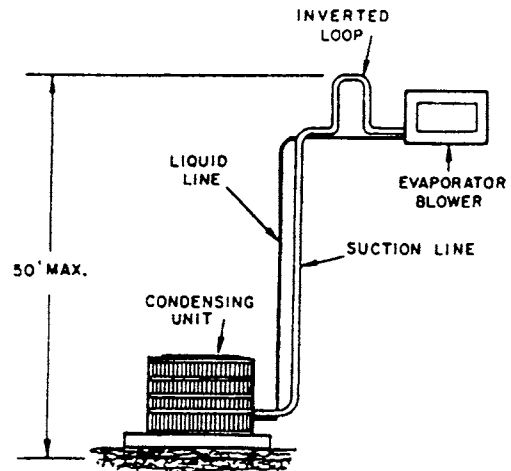

Oil Return. To facilitate oil return to the compressor a horizontal suction line should be pitched (1/2" per 10') toward the condensing unit.

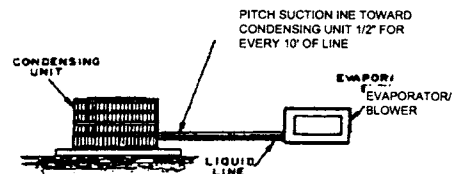

**Condenser Above the Evaporator** When the condenser is located 4' or greater above the evaporator section suction line oil trap is to be used at the base of the riser. An additional oil trap is to be added for each 20' of vertical riser. See the following sketch.

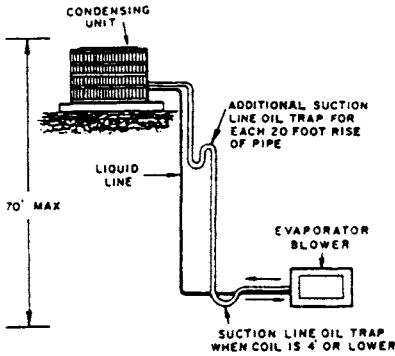

**Filter Drier and Sight Glass.** A liquid line filter drier is factory installed. A Sight Glass/Moisture indicator is provided with the unit. This is to be field installed on the liquid line as close as practical to the service valve.

**Holding Charge.** The CKL series is factory shipped with a 2 lb. R-22 holding charge. When welding introduce an inert gas (i.e. nitrogen) through the tubing to prevent the formation of copper oxide inside the tubing.

**TXV.** For improved refrigerant management, the evaporator coil is to be equipped with a thermal expansion valve (TXV).

**Liquid Line Solenoid.** It is recommended that a field supplied liquid line solenoid be added to the liquid line as close as possible to the evaporator coil. The solenoid is to be wired to close when the compressor stops to prevent refrigerant migration in the "OFF" cycle.

**Evacuation and Charging.** See the "Evacuation and Charging" section of this manual for these instructions.

## XI. Electrical Wiring

### WARNING

Before servicing or installing this equipment, the electrical power to this unit **must** be in the "OFF" position. Caution, more than one disconnect may exist. Failure to observe this warning may result in an electrical shock that can cause personal injury.

The unit **must** have an uninterrupted, unbroken electrical ground to minimize the possibility of personal injury if an electrical fault should occur. The electrical ground circuit may consist of an appropriately sized electrical wire connecting the ground lug in the unit control box wire to the building electrical service panel. Other methods of grounding are permitted if performed in accordance with the "National Electric Code" (NEC)/"American National Standards Institute" (ANSI)/"National Fire Protection Association" (NFPA) 70 and local/state codes. In Canada, electrical grounding is to be in accordance with the Canadian Electric Code CSA C22.1. Failure to observe this warning can result in electrical shock that can cause personal

injury.

### WARNING

To avoid the risk of fire or equipment damage use only copper conductors.

**Inspection of the Building Electrical Service.** This unit is designed for 3-phase operation. **DO NOT OPERATE ON A SINGLE PHASE POWER SUPPLY.** Measure the power supply to the unit. The supply voltage **must** be in agreement with the unit nameplate power requirements and within the range shown below:

Model	Minimum Supply Voltage	Maximum Supply Voltage
CKL090-3	187	253
CKL090-4	414	506
CKL120-3	187	253
CKL120-4	414	506

**Voltage Balance** The supply voltage shall be unbalance (phase to phase) within 2%. To calculate the percentage of voltage unbalance use the following formula:

$$\text{Percentage Voltage Unbalance} = 100 \times \frac{\text{Max Voltage Deviation From Avg. Voltage}}{\text{Avg. Voltage}}$$

*Example*

$$\begin{aligned} L1 - L2 &= 220 \text{ V} \\ L2 - L3 &= 216 \text{ V} \\ L1 - L3 &= 213 \text{ V} \\ \text{Avg. Voltage} &= (220 + 216 + 213) / 3 \\ &= 649 / 3 \\ &= 216 \\ \text{Max. Deviation from Avg.} &= 220 - 216 = 4 \\ \% \text{ Voltage Unbalance} &= 100 \times (4 / 216) \\ &= 400 / 216 \\ &= 1.8\% \end{aligned}$$

**Determine Wire Size** The selection of the appropriate supply wire size is important to the operation of the equipment. When selecting the wire size the following are important elements of the decision:

- The wire size is sufficient to carry the Minimum Circuit Ampacity (MCA). The unit MCA can be found on the equipment S&R plate and the following table.

Model	MCA
CKL090-3	37.8
CKL090-4	18.8
CKL120-3	43.3
CKL120-4	22.2

- The wire size is appropriately sized to allow for no more than a 2% voltage drop from the building breaker/fuse panel to the unit.
- Refer to the latest edition of the National Electric Code or in Canada the Canadian Electric Code when determining the correct wire size. The following table shows the current carrying capabilities for copper conductors rated at 75°C with a 2% voltage drop.

Max. Allowable length in Feet to Limit Voltage drop to 2%								
Wire Size (AWG)	Min. Circuit Ampacity (MCA) – CKL Unit							
	10	15	20	25	30	35	40	45
14	75	50	37	NR	NR	NR	NR	NR
12	118	79	59	47	NR	NR	NR	NR
10	188	125	95	75	63	54	NR	NR
8	301	201	150	120	100	86	75	68
6	471	314	235	188	157	134	118	110

Based on NEC 1996

**Example**

A CKL090-3 is to be installed. The distance from the building breaker box to the unit is 75'. Calculate the minimum wire size assuming no more than 2% voltage drop.

MCA for CKL120-3 = 43.3 (from S&R plate and table).

Applying previous table wire sizes less than #8 AWG cannot be used for circuits which have a rating of 45A. The #8 wire is not suitable since the maximum length for a 45A circuit is 68'. Solution, a #6 AWG wire is suitable up to 110'. Note: It is the contractors responsibility to follow the NEC (USA) or CEC (Canada) when sizing the service wire for this unit.

**Service Disconnect Box.** A service disconnect box is required as per NEC.

**Fuse – HACR Breakers**

Protection provided by either fuses or HACR type breakers. Refer to the unit S&R plate and the following table for the maximum overcurrent protection permitted.

Model	*Max. Fuse
CKL090-3	60
CKL090-4	30
CKL120-3	60
CKL120-4	35

\* Fuse or HACR Breaker of same value.

**Line Voltage Wiring** ALL line voltage wiring is to be run through conduit from the service disconnect box to the unit. Refer to the NEC (in Canada CEC) for the correct size conduit based on the wire size. The conduit is to enter the control box through the hole provided in the bottom. Note: hole is sized for 3/4" conduit. If permitted by code flexible conduit is preferred to minimize vibration transmission from the unit to the building.

Connect the line voltage wires to the L1, L2, and L3 terminals of the definite purpose contactor (located in the unit control box). Refer to the wiring diagram attached to the unit when making these connections. Note... the unit wiring diagram is also included at the end of this manual.

As noted elsewhere in this manual this unit must be grounded. The electrical ground circuit may consist of an appropriately sized electrical wire connecting the ground lug in the unit control box wire to the building electrical service panel. Other methods of grounding are permitted if performed in accordance with the "National Electric Code" (NEC)/"American National Standards Institute" (ANSI)/"National Fire Protection Association" (NFPA)

70 and local/state codes. In Canada, electrical grounding is to be in accordance with the Canadian Electric Code CSA C22.1.

**Low Voltage Connections** The CKL requires a 2-conductor low voltage circuit from the room thermostat. The wires are to be no smaller than 18 AWG. The field connection for this circuit is to be made in the unit control box using solderless connectors such as wire nuts. See the following diagram for a typical low voltage hook-up.

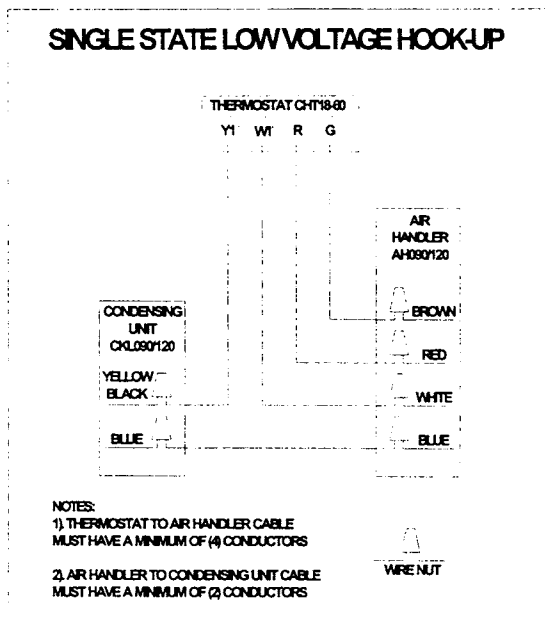

**Control Box Components** See the following for the location of the electrical components.

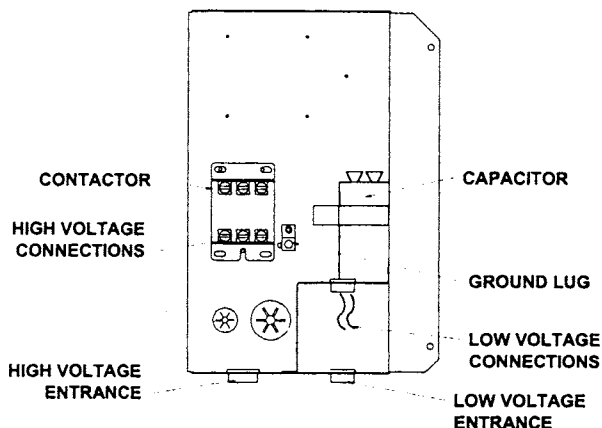

## XII SYSTEM EVACUATION AND CHARGING

### WARNING

To avoid possible explosion, death, or injury, practice safe handling of refrigerants.

While these items will not cover every conceivable situation, they should serve as a useful guide:

Refrigerants are heavier than air. They can "push out" the oxygen in your lungs or in any enclosed space. To avoid possible death or difficulty in breathing.

- Never sniff refrigerant.
- Never purge refrigerant .

If an indoor leak is suspected, thoroughly ventilate the area before beginning work.

Liquid refrigerant can be very cold. To avoid possible frostbite or blindness, avoid contact and wear gloves and goggles. If liquid refrigerant does contact your skin or eyes, get medical help immediately.

Always follow EPA regulations. Never burn refrigerant, as poisonous gas will be produced.

To avoid possible explosion, use refrigerant cylinders properly:

- If you must heat a cylinder for faster charging, partly immerse it in warm water. Never apply flame or steam to the cylinder.
- Store cylinders in a cool, dry place. Never use a cylinder as a platform or a roller.
- Never add anything other than R-22 to an R-22 cylinder.
- Never fill a cylinder more than 80% full of liquid refrigerant.
- When removing refrigerant from a system, use only returnable (not disposable) service cylinders. Check the cylinder for its pressure rating and hydrostatic test date. Check the cylinder for any damage, which may lead to a leak or explosion. If in doubt, do not use the cylinder.

### LEAK TESTING

### WARNING

To avoid the risk of fire or explosion never use oxygen high pressure or flammable gasses for leak testing of a refrigeration system.

1. Be sure both hand valves on the gauge manifold are closed relative to the center port (i.e., turned in all the way.) Attach this gauge manifold to the service valves on the unit.

### WARNING

To avoid possible explosion the line from the nitrogen cylinder must include a pressure regulator and a pressure relief valve. The pressure relief valve must be set to open at no more than 150 psig.

2. Connect a cylinder of dry nitrogen to the center port on the gauge manifold.
3. Open the hand valve a minimal amount on the line coming from the nitrogen cylinder.
4. Open the high pressure valve on the gauge manifold. Pressurize the refrigerant lines and the indoor coil to 150 psig (1034 kPA). To reach 150 psig, you may need to

### WARNING

To avoid possible explosion or equipment damage do not exceed 150 psig when pressure testing

After you reach 150 psig, close the valve on the nitrogen cylinder. Disconnect it from the gauge manifold. If you plan to use an electronic leak detector, add a trace of R-22 to the system (if permitted by current EPA regulations).

5. Apply a soap solution on all connections and joints. If you see bubbles, you have a leak. Mark these locations.
6. Use the gauge manifold to carefully release the nitrogen from the system. If leaks were found, repair them. After repair, repeat the above pressure test. If no leaks exist, proceed to system evacuation.

### SYSTEM EVACUATION

1. Connect the vacuum pump, high vacuum manifold set with high vacuum hoses, thermocouple vacuum gauge and charging cylinder as shown. Begin with all valves fully closed.

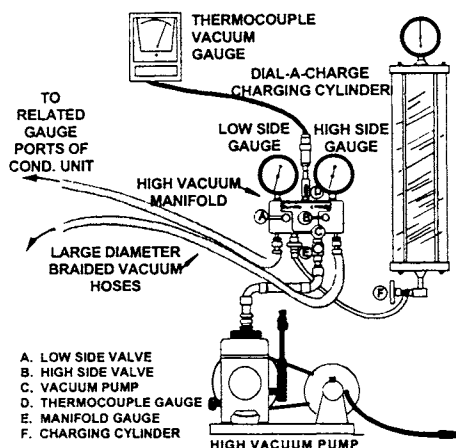

2. If service dill valves are used for evacuation, use a core remover to lift the valve core. It provides greater efficiency.
3. Confirm proper pump and gauge operation. Open the shutoff valve that leads to the high vacuum gauge manifold. Start the pump. When the compound gauge (low side) reading drops approximately 29 inches of vacuum, open the valve to the thermocouple vacuum gauge and evacuate until the gauge reads 250 microns or less.
4. Close the valve to the thermocouple vacuum gauge. This avoids potential gauge damage from "pegging the meter".
5. Open the high and low side valves on the gauge manifold. Keeping the valve on the charging cylinder closed, open the valve on the gauge manifold that leads to the cylinder.
6. Evacuate the system to about 29 inches Hg as measured by the compound (low side) gauge.
7. Open the valve to the thermocouple vacuum gauge. Evacuate until the gauge reads 250 microns or less.
8. Close the valve to the vacuum pump. Wait five minutes, then check the pressure on the thermocouple vacuum gauge:
  - If the pressure is not more than 1500 microns, the system is leak-free and properly evacuated. Proceed to Step 9.
  - If the pressure rises, but holds at about 5000 microns, moisture and non-condensibles are still present. Open the valve to the vacuum pump, and go back to Step 7.
  - If the pressure rises above 5000 microns, a leak is present. Go back to "Leak Testing" section above
9. Close the valve to the thermocouple vacuum gauge. Close the valve to the vacuum pump. Shut off the pump.

#### PRELIMINARY CHARGE ADJUSTMENT

**IMPORTANT:** See the wiring diagram or outdoor unit specification sheet to determine if this unit has a crankcase heater. If it does, you must connect electrical power to the unit for four hours before operating the compressor. Failure to do so could result in compressor damage.

**IMPORTANT:** During all installation and service work, follow all regulations of the Environmental Protection Agency. (This system uses R-22 - an HCFC [Hydrogenated Chlorofluorocarbon].) Violation of EPA regulations may result in fines or other penalties.

Use a male hex head wrench (5/16" for liquid) to carefully open the liquid valve stem on the unit. Use a service wrench or crescent wrench to open the suction ball valve. The valve is fully open with a 90° turn (i.e. the stem is inline with the valve flow direction).

The outdoor unit is factory charged with 2 lb. R-22.

**IMPORTANT:** Use only refrigerant, which is certified to meet ARI Standard 700. Used refrigerant may cause compressor damage, and will void the warranty. (Most portable machines cannot clean used refrigerant well enough to meet this ARI Standard.)

**IMPORTANT:** When adding additional refrigerant to a system, add only refrigerant vapor (not liquid) through the suction valve (low side) on the outdoor unit. Any other practice may cause compressor damage.

#### FINAL CHARGE ADJUSTMENT

**IMPORTANT:** Never operate the compressor with the suction valve closed to "test the compressor's pumping efficiency". In some cases, this can result in serious compressor damage and loss of warranty coverage.

For 25' of line set the 7-1/2 ton charge is approximately 17 lb. For 25' of line set the 10 ton is approximately 20 lb. of R-22. **DO NOT start with these amounts.**

For installation greater than 25' of line set, indoor unit airflow, condensing unit location and number of tubing fittings will have an impact on final unit charge amount. Start with half of the 25' line set charge and proceed.

Turn the electrical power on, and let the system run. Wait for the refrigerant pressures to stabilize.

#### EXPANSION VALVE INDOOR COILS:

**NOTE:** EXPANSION VALVE BULB, MUST BE IN PLACE ON SUCTION LINE & INSULATED.

At stabilized cooling conditions and with an outdoor temperature of 60°F or higher, the system should have from 9°F to 13°F subcooling. For a proper subcooling reading, measure the refrigerant pressure and temperature at the outdoor unit's liquid line service valve. If you have less than 9°F subcooling, add charge. If you have more than 13°F subcooling, remove charge.

While reaching the proper subcooling level it is important to know the discharge line temperature to know the discharge line temperature. This temperature should be at least 80°F over ambient or unit is flooding back to compressor. If flooding (i.e. low discharge line temperature) occurs, adjust valve stem on expansion valve inward (clockwise viewing end of expansion valve). This will increase the super heat.

After achieving the proper subcooling and a sufficient discharge temperature, make small adjustment to expansion valve stem to reach 8° to 10°F of super heat. Adjusting the valve stem in



clockwise, superheat increase, adjusting the valve stem out, counter clockwise, super heat decreases. If the system is performing properly, reinstall the service port caps and the valve bonnets. With the valve opened, the valve bonnet is the primary seal against refrigerant leaks. Apply two drops of clean oil to the cap threads, allowing the oil to run down to the inner cap seal surface. Close caps finger-tight. Then tighten cap additional two to three hex flats.

**Note:** Subsequent opening and replace of the cap will require only 1/2 to 1 hex flat. See the table below for the torque required for an effective seal on the valve bonnet (1/6 turn past finger tight).

Tube Size	Torque (Foot-Pounds)
5/8	14
1 3/8	16

After closing the valve bonnet, perform a final refrigerant leak test on the valves and sweat connections. Return the room thermostat to the desired settings.

### XIII TROUBLE SHOOTING

#### QUALIFIED INSTALLER/SERVICER ONLY

When troubleshooting, the first step should always be to check for clean coils, clean filter(s), and proper airflow. Indoor airflow should be 375 to 425 CFM per ton of cooling based on the size of the outdoor unit. The most common way of establishing indoor airflow is heating temperature rise. Indoor airflow will then be (Heating output of equipment) / (1.1 x temp. rise). In other cases, measurement of external static pressure is helpful. For details, see the Installation Operator Instructions for your indoor equipment.

#### Caution – 3 Phase Scroll Compressor

The CKL90/120 condenser is equipped with a 3-phase scroll compressor. If the unit sounds noisy and/or the suction and liquid pressures are almost equal the compressor is operating in the reverse rotation. Reverse (2) incoming power supply leads.

### TROUBLE SHOOTING ANALYSIS TABLE

COMPLAINT	PROBABLE CAUSE	REMEDY
1. High Head Pressure	<ol style="list-style-type: none"> <li>Excessive charge of refrigerant in system.</li> <li>Inadequate supply of air across the condenser coil.</li> <li>Non-condensate gases in the system.</li> </ol>	<ol style="list-style-type: none"> <li>Purge or pump-down excessive charge.</li> <li>Make certain that coil is not fouled in any way, or that air is not re-circulating.</li> <li>Purge these gases from the system. Recharge system, if necessary.</li> </ol>
2. Low Head Pressure	<ol style="list-style-type: none"> <li>System low on refrigerant.</li> <li>Compressor valves broken.</li> </ol>	<ol style="list-style-type: none"> <li>Charge system until sight glass is clear of bubbles.</li> <li>Replace compressor.</li> </ol>
3. Low Suction Pressure	<ol style="list-style-type: none"> <li>Liquid line valve closed.</li> <li>Restricted liquid line.</li> <li>The bulb of the thermal expansion valve has lost its charge.</li> <li>System low on refrigerant.</li> <li>Dirty filters.</li> <li>Coil frosted up.</li> <li>Flash gas in the liquid line.</li> <li>Quantity of air through evaporator not adequate.</li> </ol>	<ol style="list-style-type: none"> <li>Open the liquid line valve.</li> <li>Replace filter-dryer.</li> <li>Detach the bulb from the suction line and hold in one hand. If no liquid refrigerant goes through the valve, replace the valve.</li> <li>Test the unit for leaks. Add refrigerant until sight glass is free from bubbles, after repairing leak.</li> <li>Clean or replace filter.</li> <li>Defrost and clean coil. Clean or replace filters.</li> <li>Excessive liquid line drop. Check liquid line size.</li> <li>Increase the blower speed.</li> </ol>
4. High Suction Pressure	<ol style="list-style-type: none"> <li>Expansion valve stuck open.</li> <li>Expansion valve bulb not in contact with suction line.</li> <li>Suction and/or discharge valve leaking or broken.</li> </ol>	<ol style="list-style-type: none"> <li>Correct valve action or replace the valve.</li> <li>Fasten bulb lightly to suction line.</li> <li>Replace compressor.</li> </ol>
5. Compressor will not start.	<ol style="list-style-type: none"> <li>Disconnect switch open.</li> <li>Blow fuse or fuse at disconnect switch.</li> <li>Thermostat set too high.</li> <li>Selector switch in "Off" position.</li> <li>Contact and/or relay coils burned out.</li> <li>Loose or open electrical connection in either the control or power circuit.</li> </ol>	<ol style="list-style-type: none"> <li>Close the disconnect switch.</li> <li>Check the cause of failure and replace the fuse.</li> <li>Adjust to lower temperature.</li> <li>Turn selector switch knob to "Cool" position.</li> <li>Replace contact and/or relay.</li> <li>Inspect and secure all electrical connections.</li> </ol>

#### XIV WIRING DIAGRAM

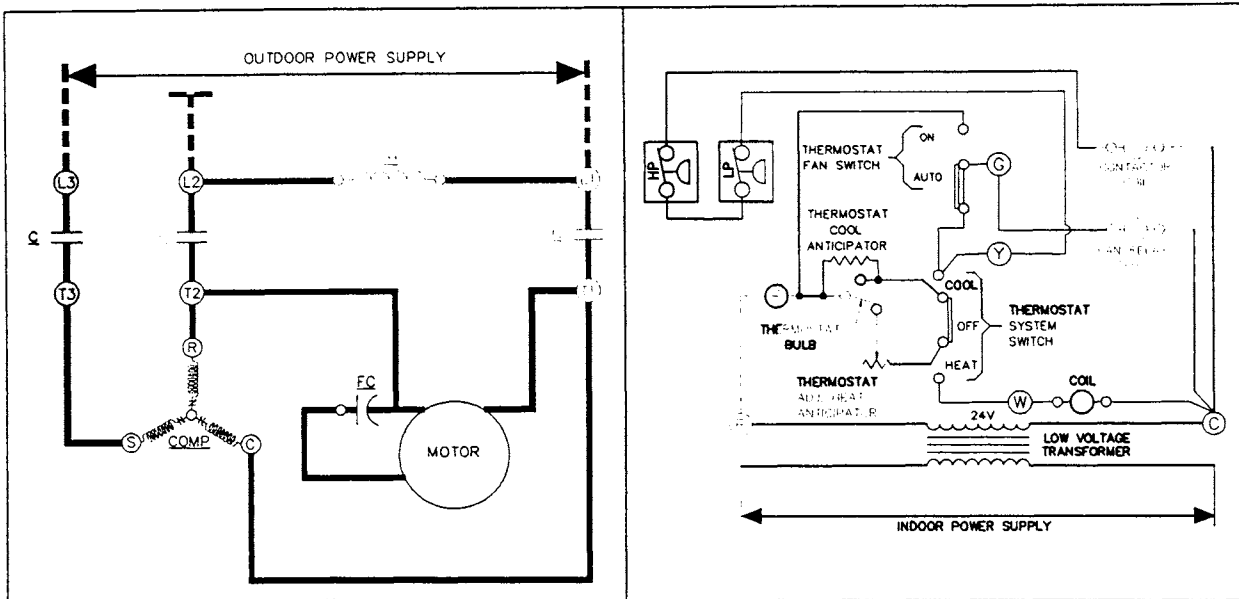

### Quality Makes the Difference!

All of our systems are designed and manufactured with the same high quality standards regardless of size or efficiency. Our designs virtually eliminate the most frequent causes of product failure. They are simple to service and forgiving to operate. We use the highest quality materials and components available because if a part fails then the unit fails. Finally, every unit is run tested before it leaves our factory. That's why we know.....

### There's No Better Quality

For additional information visit our web site at [www.goodmanmfg.com](http://www.goodmanmfg.com) for information on:

- Goodman Manufacturing Products
- Warranties
- Customer Services
- Parts
- Contractor Programs and Training
- Financing Options