

INSTALLATION & OPERATING INSTRUCTIONS

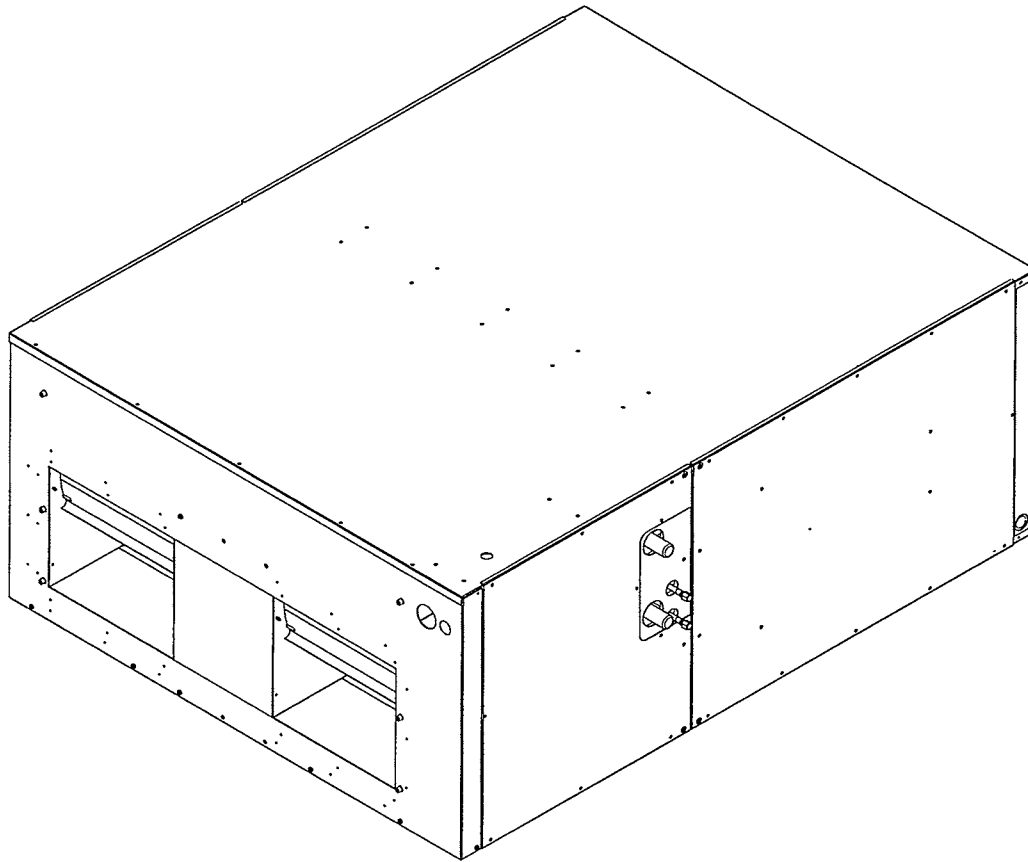

AR090 & AR120 SERIES COMMERCIAL AIRHANDLER

Goodman Manufacturing Company, LP
2550 North Loop West, Suite 400
Houston, TX 77092
USA

I General Warnings

WARNING

Before servicing or installing this equipment, the electrical power to this unit **must** be in the "OFF" position. Caution, more than one disconnect may exist. Failure to observe this warning may result in an electrical shock that can cause personnel injury.

WARNING

The unit **must** have an uninterrupted, unbroken electrical ground to minimize the possibility of personnel injury if an electrical fault should occur. The electrical ground circuit may consist of an appropriately sized electrical wire connecting the ground lug in the unit control box wire to the building electrical service panel. Other methods of grounding are permitted if performed in accordance with the "National Electric Code" (NEC)/"American National Standards Institute" (ANSI)/"National Fire Protection Association" (NFPA) 70 and local/state codes. In Canada, electrical grounding is to be in accordance with the Canadian Electric Code CSA C22.1. Failure to observe this warning can result in electrical shock that can cause personnel injury.

WARNING

Due to high system pressure and electrical shock potential, installing and the servicing air conditioning systems can be hazardous. **ONLY TRAINED AND QUALIFIED PERSONNEL ARE PERMITTED TO INSTALL OR SERVICE THIS EQUIPMENT.** Observe ALL warnings contained in this manual and labels/tags attached to the equipment.

WARNING

This product is factory shipped for use with a 208-230/3/60 electrical power supply. However, the airhandler can be reconfigured to operate with a 460/3/60 power supply provided the conversion noted in section "Conversion to 460 Electrical Supply" section of this manual is performed.

WARNING

This airhandler is designed for Upflow or Horizontal – Left applications. **DO NOT INSTALL IN THE DOWNFLOW OR HORIZONTAL –RIGHT ORIENTATION.**

When installing or servicing this equipment safety clothing including hand and eye protection is strongly advised. If installing this equipment in an area that has special safety requirements (hard hats etc.) observe these requirements. To protect the unit when welding close to the painted surfaces the use of a quenching cloth is strongly advised to prevent scorching or marring of the equipment finish.

Read these instructions before performing this installation or servicing this unit. All installations must be in accordance with all national, state, or local building codes.

II Model Identification

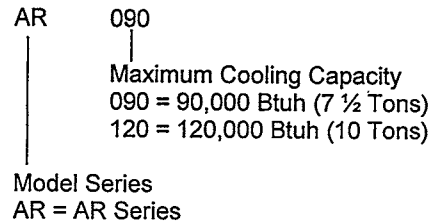

III Product Description

When matched with CKL090 and CKL120 condenser this system complies with the minimum efficiency requirements found in ASHRAE 90.1-1999. See the Goodman CKL90 and CKL120 specification sheet for details on these condensers. For other Goodman condenser(s) that can be matched with this airhandler to obtain ASHRAE 90.1-1999 compliance, consult with your local distributor

The AR series are intended for use with a room thermostat. This thermostat is not supplied with this equipment. Only thermostats that use 24 VAC control circuitry are to be used.

	AR090	AR120
Net Weight (Lbs.)	375	400
Shipping Weight (Lbs.)	405	430
Refrigerant	R22	
Blower Wheel (Dia x Width)	11 x 10	
Blower Wheel Quantity	2	
Motor Type	Belt Drive	
Motor Qty	1	
Motor (HP)	1 ½	2
Motor (RPM)	1750	
Motor Sheave Type	Adjustable Variable Pitch	
Motor Sheave Diameter (in)	1.9" – 2.9"	2.8" – 3.8"
Blower Wheel Pulley Type	Fixed Diameter	
Blower Wheel Pulley Dia (in)	5.9	6.5
Evaporator Coil Material	Copper Tubes / Al Fins	
Face Area (Ft ²)	8.9	10.0
Number of Rows	4	4
Suction Line Quantity	1	2
Suction Line Connection (in) *	1 1/8	
Liquid Line Quantity	1	2
Liquid Line Connection (in)*	5/8	3/8
Metering Device	Thermal Expansion Valve (TXV)	
TXV Type	Adjustable	
TXV Quantity	1	2

* Note: Consult with the condenser specifications for suction and liquid line sizing.

IV. Unit Inspection

Upon delivery, the unit is to be inspected for damage. Any damage must be reported immediately to the carrier. Do not install this equipment if it is determined that the integrity or safety has been compromised by freight damage.

Using the table "Model Identification" section check the equipment model number to ensure the unit is appropriately sized for the condenser unit(s).

If an incorrect unit is supplied it must not be installed and it is to be returned to the supplier. The manufacturer assumes no responsibility for the installation of incorrect delivered units.

The evaporator coil contains a high-pressure inert gas holding charge. Before installing the unit it is strongly recommended that the liquid line Schrader fitting(s) are depressed to verify the integrity of the evaporator coil. Note: the AR120 has (2) liquid line Schrader valves each of which is to be tested.

V. Electric Heat

WARNING

Refer to the "INSTALLING ELECTRIC HEAT" section of this manual and the instructions provided with the heat kit for the correct installation procedure.

WARNING

The electrical characteristics of the airhandler, the electric heat kit, and the building power supply must agree.

This air handler does not have factory installed electric heat. Electric heat is available as an accessory. If installing this option the **ONLY** heat kits that can be used is the AHKD series as indicated below:

AHKD Model Number	Nominal KW	Electrical Characteristics	Stages
AHKD15-3	15	208-230/3/60	1
AHKD15-4	15	460/3/60	1
AHKD20-3	20	208-230/3/60	2
AHKD20-4	20	460/3/60	2
AHKD30-3	30	208-230/3/60	2
AHKD30-4	30	460/3/60	2

For all supply voltages use the correction factors in the following tables multiplied by KW and (or) temperature rise to have corrected results.

KW Correction Factors (-3 models)

Supply Voltage	240	230	220	210	208
Correction Factor	1.0	0.92	0.84	0.77	0.75

KW Correction Factors (-4 models)

Supply Voltage	480	460	440	415	380
Correction Factor	1.0	0.92	0.84	0.75	0.63

The heating mode temperature rise is dependent upon the system airflow, the supply voltage, and the heat kit size (KW) selected. Use the following table to determine the temperature rise (°F):

AR090 Temperature Rise Table (Degrees F)

Airhandler	Heat Kit KW	CFM	Supply Voltage		
			208	240	480
AR090	15	2800	14	19	19
		2900	14	18	18
		3000	13	18	18
		3100	13	17	17
		3200	12	17	17
	20	2800	19	25	25
		2900	18	24	24
		3000	18	24	24
		3100	17	23	23
		3200	17	22	22
	30	2800	28	38	38
		2900	27	37	37
3000		27	35	35	
3100		26	34	34	
3200		25	33	33	

AR120 Temperature Rise Table (Degrees F)

Airhandler	Heat Kit KW	CFM	Supply Voltage		
			208	230	460
AR120	15	3800	10	14	14
		3900	10	14	14
		4000	10	13	13
		4100	10	13	13
		4200	9	13	13
		4200	9	13	13
	20	3800	14	19	19
		3900	14	18	18
		4000	13	18	18
		4100	13	17	17
		4200	13	17	17
		4200	13	17	17
	30	3800	21	28	28
		3900	20	27	27
		4000	20	27	27
		4100	19	26	26
		4200	19	25	25
		4200	19	25	25

Note: The preceding table is calculated with both stages of electric heat engaged (2 stage heat systems). For systems using staged electric heat, divide the temperature rise from the table by 2 for 1st stage operation.

VI. Orientation

The AR series of Airhandlers can be mounted in the following orientations:

- Upflow
- Horizontal - Left Hand

DO NOT INSTALL THIS AIRHANDLER IN THE HORIZONTAL -RIGHT OR DOWNFLOW ORIENTATION.

Location

WARNING

The AR series of airhandlers is designed for indoor installations only. DO NOT INSTALL OUTDOORS.

WARNING

When installing this airhandler in an enclosed area, such as a garage/parking area, with any carbon monoxide producing device (i.e. an automobile, space heater, water heater etc.) insure that the area is properly ventilated.

The AR airhandler is suitable for installation in multiple locations including:

- Overhead (Attic/Mezzanine etc)
- Closet/Mechanical Room

When installing this airhandler consideration to minimize the length of refrigerant tubing is to be given. Also, do not install the airhandler in a location either above or below the condenser that violates the instructions provided with the condenser.

The clearance from a combustible surface to the unit is 0". However, service clearance is to take precedence. Allow a minimum of 36" in front of the unit for service clearance. Allow sufficient clearance to remove heater elements for service or replacement in heat kits when utilized in application.

When installing in an area directly over a finished ceiling (such as an attic) an emergency drain pan is required directly under the unit. See local and state codes for additional requirements.

When installing this unit in an area that may become wet elevate the unit with a sturdy, none porous material.

In installations that may lead to physical damage (warehouse, industrial sites etc) it is advised to install a protective barrier to prevent such damage.

VII. Ductwork

The AR series of airhandlers are designed for a complete supply and return ductwork system. DO NOT OPERATE THIS PRODUCT WITHOUT BOTH DUCTWORK ATTACHED.

To ensure correct system performance the ductwork is to be sized to accommodate 375-425 CFM per ton of cooling with the static pressure not to exceed .5" WC. Inadequate ductwork that restricts airflow can result improper cooling performance and compressor failure. Ductwork is to be constructed in a manner that limits restrictions and maintains suitable air velocity. Ductwork is to be sealed to the unit in a manner that will prevent leakage.

Supply Ductwork Flanges. The supply ductwork flanges are shipped loose and required to be field installed. See the

following sketch for further details: Dimensions are approx. 40" x 13-1/8"

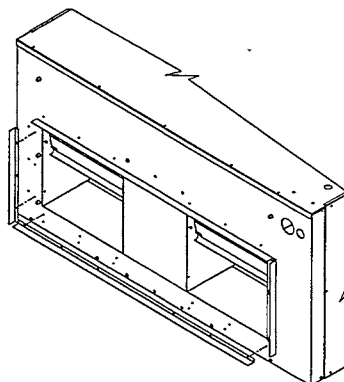

Return Ductwork. DO NOT TERMINATE THE RETURN DUCTWORK IN AN AREA WHICH CAN INTRODUCE TOXIC, OR OBJECTIONABLE FUMES/ODORS INTO THE DUCTWORK. The return ductwork is to be introduced into the airhandler bottom. The cabinet dimensions are 48" x 24".

Return Air Filters. This unit is factory equipped with disposable return air filters. To ensure optimum performance frequent filter replacement is advised. See the following table for the factory installed filter sizes:

Model	Filter Size (in)	Qty
AR090	16 x 20 x 2	4
AR120	16 x 20 x 2	2
	20 x 20 x 2	2

IX. Electrical Supply Wire and MOP

WARNING

Before servicing or installing this equipment, the electrical power to this unit **must** be in the "OFF" position. Caution, more than one disconnect may exist. Failure to observe this warning may result in an electrical shock that can cause personnel injury.

WARNING

The unit **must** have an uninterrupted, unbroken electrical ground to minimize the possibility of personnel injury if an electrical fault should occur. The electrical ground circuit may consist of an appropriately sized electrical wire connecting the ground lug in the unit control box wire to the building electrical service panel. Other methods of grounding are permitted if performed in accordance with the "National Electric Code" (NEC)/"American National Standards Institute" (ANSI)/"National Fire Protection Association" (NFPA) 70 and local/state codes. In Canada, electrical grounding is to be in accordance with the Canadian Electric Code CSA C22.1. Failure to observe this warning can result in electrical shock that can cause personnel injury.

WARNING

To avoid the risk of fire or equipment damage use only copper conductors.

WARNING

THIS PRODUCT IS CAPABLE OF USING EITHER 208-230/3/60 OR 460/3/60 SUPPLY VOLTAGE. THIS AIR HANDLER IS FACTORY SHIPPED FOR USE WITH 208-230/3/60 VOLTAGE. INSTALLATIONS USING 460/3/60 REQUIRING MODIFICATION TO THE MOTOR AND TRANSFORMER ELECTRICAL CIRCUITS. REFER TO THE "CONVERSION TO 460V POWER SUPPLY" SECTION OF THIS MANUAL. DO NOT OPERATE THIS APPLIANCE USING A 460V POWER SUPPLY UNLESS THIS MODIFICATION HAS BEEN MADE. FAILURE TO OBSERVE THIS WARNING MAY RESULT IN PERSONAL INJURY, EQUIPMENT DAMAGE AND FIRE.

Inspection of the Building Electrical Service. This unit is designed for 3-phase operation. DO NOT OPERATE ON A SINGLE PHASE POWER SUPPLY. SEE THE "WARNING" ABOVE". Measure the power supply to the unit. The supply voltage **must** be in agreement with the unit nameplate power requirements and within the range shown below:

Nominal	Minimum Supply Voltage	Maximum Supply Voltage
208 - 230	187	253
460	414	506

Voltage Balance The supply voltage shall be unbalance (phase to phase) within 2%. To calculate the percentage of voltage unbalance use the following formula:

$$\text{Percentage Voltage Unbalance} = 100 \times \frac{\text{Max Voltage Deviation From Average Voltage}}{\text{Average Voltage}}$$

Example

$$\begin{aligned} L1 - L2 &= 220 \text{ V} \\ L2 - L3 &= 216 \text{ V} \\ L1 - L3 &= 213 \text{ V} \\ \text{Avg. Voltage} &= (220+216+213) / 3 \\ &= 649 / 3 \\ &= 216 \end{aligned}$$

$$\text{Max. Deviation from Avg.} = 220 - 216 = 4$$

$$\begin{aligned} \% \text{ Voltage Unbalance} &= 100 \times (4 / 216) \\ &= 400 / 216 \\ &= 1.8\% \end{aligned}$$

Determine Wire Size The selection of the appropriate supply wire size is important to the operation of the equipment. When selecting the wire size the following are important elements of the decision:

- The wire size is adequately sized to carry the Minimum Circuit Ampacity (MCA). Refer to the NEC (USA) or CSA (Canada) for wire sizing. The unit MCA for the airhandler and the optional electric heat kit can be found on the

equipment S&R plate and the following table.

AIR HANDLER	VOLTAGE	HEAT KIT	MCA
AR090	208-230	None	6.5
		AHKD15-3	48.6
		AHKD20-3	63.0
	460	None	3.3
		AHKD15-4	24.3
		AHKD20-4	31.5
AR120	208-230	None	7.5
		AHKD15-3	49.4
		AHKD20-3	63.8
	460	None	3.8
		AHKD15-4	24.7
		AHKD20-4	31.9
	AHKD30-4	46.4	

- The wire size is appropriately sized to allow for no more than a 2% voltage drop from the building breaker/fuse panel to the unit.
- Refer to the latest edition of the National Electric Code or in Canada the Canadian Electric Code when determining the correct wire size. The following table shows the current carrying capabilities for copper conductors rated at 75°C with a 2% voltage drop.

Max. Allowable Length in Feet to Limit Voltage Drop to 2%

Wire Size (AWG)	Min. Circuit Ampacity (MCA)							
	10	15	20	25	30	35	40	45
14	75	50	37	NR	NR	NR	NR	NR
12	118	79	59	47	NR	NR	NR	NR
10	188	125	95	75	63	54	NR	NR
8	301	201	150	120	100	86	75	68
6	471	314	235	188	157	134	118	110

Based on NEC 1996

Maximum Overcurrent Protection (MOP)

Every installation must include an NEC (USA) or CEC (Canada) approved over current protection device. Also check with local or state codes for any special regional requirements.

This protection can be in the form of fusing or HACR style circuit breakers. The following table can be used as a guide for selecting the MAXIMUM overcurrent device. This information is also stated on the equipment S&R plate. Note: fuses or circuit breakers are to be sized larger than the equipment MCA but not to exceed the MOP listed below.

AIR HANDLER	HEAT KIT	MOP
AR090	None	15
	AHKD15-3	60
	AHKD20-3	70
	AHKD30-3	100
	None	15
	AHKD15-4	30
	AHKD20-4	35
AR120	AHKD30-4	50
	None	15
	AHKD15-3	60
	AHKD20-3	70
	AHKD30-3	100
	None	15
	AHKD15-4	30
AHKD20-4	35	
AHKD30-4	50	

A.O. SMITH 1 1/2 HP
CONVERSION TO 460V-480V

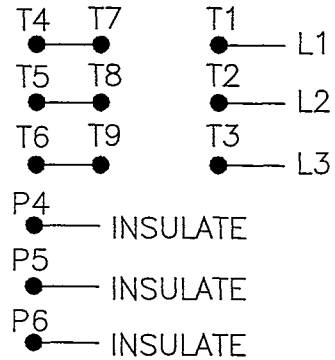

X. Conversion 460 Electrical Power Supply

WARNING

THIS PRODUCT IS CAPABLE OF USING EITHER 208-230/3/60 OR 460/3/60 SUPPLY VOLTAGE. THE AIR HANDLER IS FACTORY SHIPPED FOR USE WITH 208-230/3/60 VOLTAGE. INSTALLATIONS USING 460/3/60 REQUIRES A MODIFICATION TO THE MOTOR AND TRANSFORMER ELECTRICAL CIRCUIT. DO NOT OPERATE THIS APPLIANCE USING A 460V POWER SUPPLY UNLESS THIS MODIFICATION HAS BEEN MADE. FAILURE TO OBSERVE THIS WARNING MAY RESULT IN PERSONAL INJURY, EQUIPMENT DAMAGE AND FIRE.

It is advisable to perform this conversion in an area that will permit easy accessibility.

Transformer. The transformer is a multi rated transformer 208V, 240V, or 480V primary input.. To change from the factory setting of 230 to 460V applications remove the Orange colored wire attached to the 240 terminal on the primary side of the transformer. Install this wire on the transformer terminal marked 480. Similarly, move the Orange wire from 240 to 208 for 208V applications.

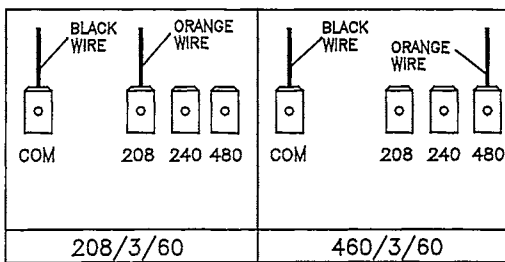

Motor Conversion This conversion requires access to the motor electrical junction box that is located on the motor endplate on the side opposite from the shaft. Use the following diagrams when performing this procedure.

AR090 Motor

AR120 Motor

A.O. SMITH 2 HP
CONVERSION TO 460V-480V

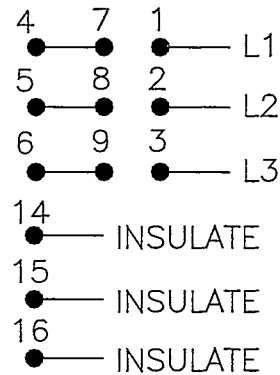

XI. Electrical Connections

Supply Voltage A single point supply voltage termination is provided in the airhandler control box (non-heat kit models) or heat kit control box (heat kit models). This termination is common to both the airhandler, and if equipped, heat kit. The wire is to be sized in accordance with the "Electrical Wire and MOP" section of this manual.

Supply Voltage - Non-Heat Kit Models. Supply wire is to be routed through conduit from the service disconnect box to the unit. The airhandler is equipped with a knockout suitable for 3/4" conduit. The following diagram illustrates the supply voltage hook-up.

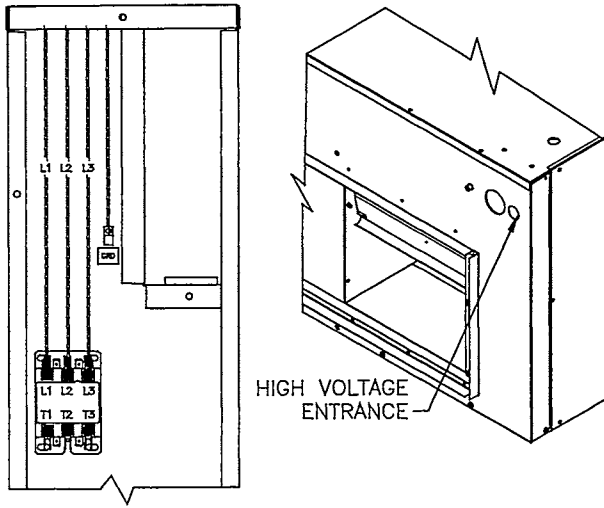

accept the low voltage wiring is provided. See the following drawings for typical low voltage connections

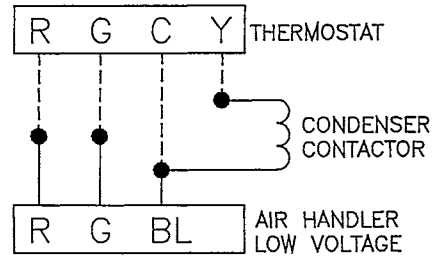

No Heat - Single Stage Cooling where R... Red, G... Green, BL.... Blue Note white wire and brown wire are not used and are to be taped.

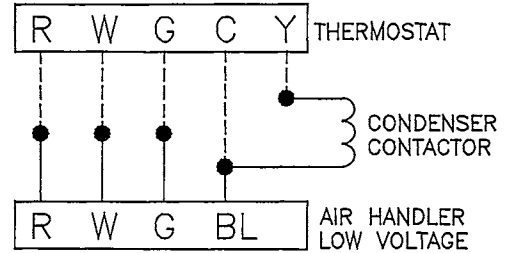

Single Stage Heat - Single Stage Cooling where R... Red, W... White, G... Green, BL.... Blue Note brown wire is not used and is to be taped.

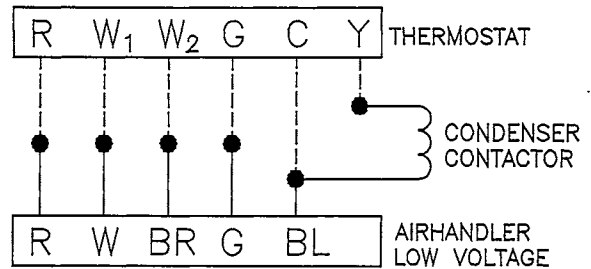

Two Stage Heat - Single Stage Cooling - where R... Red, W... White, BR... Brown, G... Green, BL.... Blue

XII. Heat Kit Installation

Inspect for Shipping Damage. The heat kit is an optional accessory that is shipped separately from the air handler. Inspect the heat kit for damage and report any damage to the carrier and/or distributor. Do not install this accessory if it is determined that the integrity or safety has been compromised by freight damage.

Check the Nameplate. From the heat kit nameplate check the

Supply Voltage - Heater Kit Models. When a heater kit is used the system uses a single point wiring hook-up. The supply wire is to be routed through conduit from the service disconnect box to the heater kit. The heat kit is equipped with a knockout suitable for 1/2" or 3/4" conduit dependent on the KW. The supply voltage is to be installed on the terminal block located in the heater kit control box.

The heater kit is factory equipped with the supply and low voltage wires for the airhandler. The low voltage connection from the heater kit is provided through a multi-pin plug which connects to a mating plug in the airhandler. The high voltage connections are to be made at the air handler contactor. These wires are to be routed through the pipe nipples supplied with the heater kit as shown below:

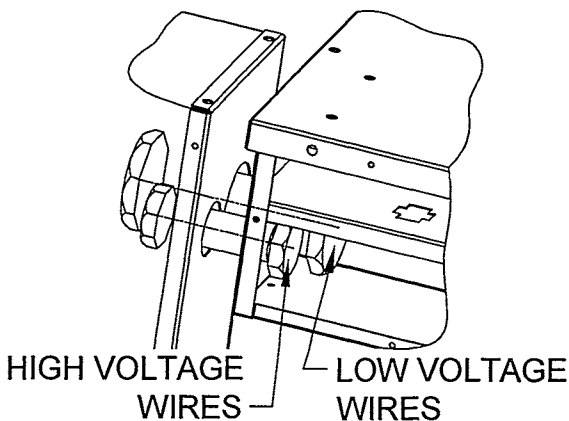

Low Voltage The 24V-control voltage connects the airhandler to the room thermostat and condenser. For systems using staged electric heat, the thermostat is to have W1 and W2 functions. Low voltage wiring is to be copper conductors, and be a minimum of 18AWG. A provision on the cabinet side to

following:

- The model number agrees with the approved models (see the "Electric Heat" section of this manual).
- The correct size (kW)
- Electric characteristics, voltage and phase, agree with the building electrical supply.

Attaching the Heat Kit The heat kit attaches directly to the top panel (when viewed in the upflow position) of the airhandler. Do not screw the heat kit into the duct flanges. See the following drawing for details:

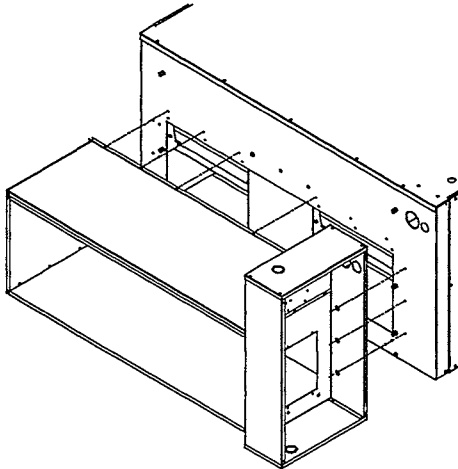

The wires from the heat kit are to be routed through the pipe nipple into the air handler electrical compartment. See the "Electrical Connection" section of this manual for wiring details.

XIII. Refrigerant Lines

WARNING

To protect the unit when welding close to the painted surfaces the use of a quenching cloth is strongly advised to prevent scorching or marring of the equipment finish.

Preparing the Tubing. All cut ends are to be round, burr free, and cleaned. Failure to follow this practice increases the chances for refrigerant leaks. The equipment suction line(s) are spun closed and requires pipe cutters to cut off the closed end. The liquid lines have a Schrader valve soldered on the end. Un-sweat the Schrader valve(s) and clean the end of these tubes.

Post Brazing. Quench all welded joints with water or a wet rag.

Piping Size For the correct size tubing follow the specification for the condenser/heat pump.

The AR090 coil is circuited to accept a single suction and liquid line. The AR120 evaporator coil has (2) suction lines

and (2) liquid lines. When using a single condenser such as the CKL120 with the AR120 it is necessary to manifold the suction lines into a single connection. Similarly, the liquid lines of the AR120 are to be manifolded when matched with a single condenser/heat pump. See the following sketch for additional details.

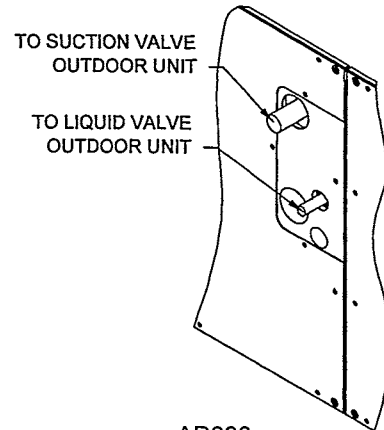

AR090

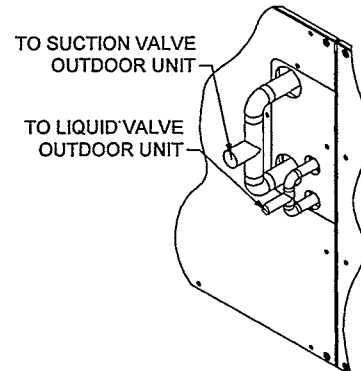

AR120 SINGLE OUTDOOR UNIT

Note: The resulting manifolds are to be sized to accept the suction and liquid line diameters prescribed within the condenser Installation Manual.

Multiple Condensers The AR120 can accept (2) condensers/heat pumps. When using two condensers use the following piping procedure:

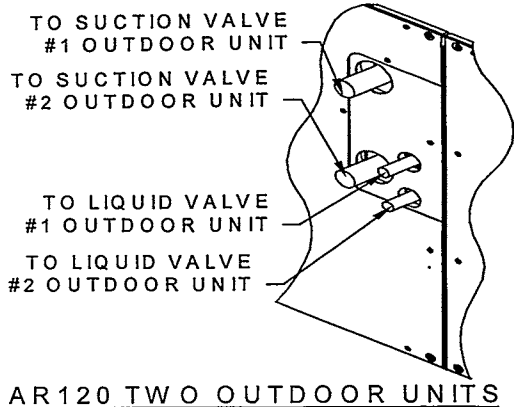

- While maintaining the fixed half of the sheave stationary rotate the other half clockwise (screw in).
- Tighten the set screw
- Reinstall the belt

To decrease the airflow perform the same as above but rotate the sheave counterclockwise (screw out).

The following table can be used as guide for system airflow:

AR090

Static Pressure	Sheave Turns Open				
	1	2	3	4	5
.1	4264	3930	3633	3273	
.2	3996	3705	3325	2998	
.3	3731	3379	3002	2517	
.4	3445	3066	2613	-	
.5	3113	2662	-	-	

AR120

Static Pres.	Sheave Turn Open					
	0	1	2	3	4	5
.1	5193	5037	4790	4529	4097	4097
.2	5012	4873	4603	4315	3842	3842
.3	4852	4675	4393	4091	3589	3589
.4	4687	4484	4172	3853	3295	3073
.5	4501	4268	3939	3561	2922	2610
.6	4293	4041	3673	3223	2642	-
.7	4073	3782	3347	2892	-	-
.8	3807	3485	2962	-	-	-
.9	3540	3117	-	-	-	-

XIV. Evaporator Coil TXV

Note: Thermal Expansion Valve (TXV) Bulb is not permanently connected to the suction from the factory. After suction and liquid line tubing is brazed in the field, the TXV bulb must be attached and insulation to the suction line(s) inside the cabinet at the 10 or 2 o'clock position. This location will be different depending on the orientation of the unit, vertical or horizontal. Always locate the TXV bulb on the top of the suction tube at 10 or 2 o'clock.

For the majority of installation, no adjustment to the TXV setting is required. However, if the measured superheat is less than 8° or greater than 20° an adjustment is required. The adjustment stem is at the base of the valve (opposite the diaphragm) under a flair nut.

To increase the superheat (when measured at the condenser base valve) turn the stem clockwise (in). Similarly to decrease the superheat turn the stem out (counterclockwise). Use a 1/4" refrigeration wrench for this function.

Check condensing unit / heat pump instructions for charging method.

XV. Airflow

The blower uses a belt drive motor that has an adjustable sheave. The factory setting for the AR090 is 2 turns open and the AR120 is 3 turns open.

To increase the airflow:

- Remove the blower belt
- Loosen the set screw as shown below

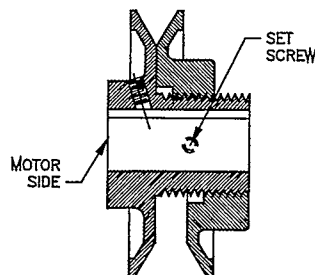

XVI. Belt Tension

The belt tension is to be checked at the time of installation and after a "run in" period of about 24 hours. To perform the measurement it is suggested that a "Belt Tension Gauge", that is available from most belt manufacturers, be used. The force required to deflect the belt 1/8" (at the midpoint) should be between 3 1/2 and 5 pounds.

XVII. Maintenance

Routine maintenance is essential for trouble free operational of this Airhandler. A few preseason checks can eliminate costly repairs and down time.

1. Check and change air filters as needed
2. Check, adjust or replace belts and check sheaves for proper operation.
3. Clean the evaporator coil and check for duct leaks.
4. Check for proper charge and (or) for refrigerant leaks.

If these few precautions are observed and maintained, this Airhandler can provide years of trouble free service

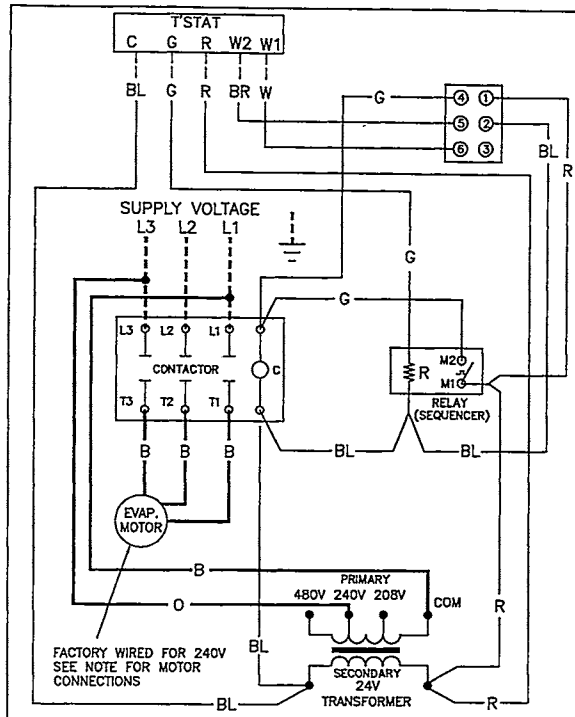

- NOTES**
- 1) ALL REPLACEMENT WIRES MUST BE SAME GAUGE AND TYPE.
 - 2) TO CHANGE VOLTAGE FROM 240V TO 208V, MOVE WIRE FROM 240V TAP TO 208V TAP AT TRANSFORMER PRIMARY.
 - 3) TO CONVERT VOLTAGE FROM 240V TO 460V:
 - a) MOVE WIRE FROM 240V TAP TO 480V TAP AT TRANSFORMER PRIMARY.
 - b) IDENTIFY MODEL (i.e. AR090 OR AR120) AND REWIRE MOTOR FROM LOW VOLTAGE (240V) TO HIGH VOLTAGE (480V) ACCORDING TO INSTRUCTION BELOW.
- COLOR CODE**
- B — BLACK
 - BL — BLUE
 - BR — BROWN
 - G — GREEN
 - O — ORANGE
 - R — RED
 - W — WHITE
- WIRING CODE**
- FACTORY WIRING —
 - HIGH VOLTAGE —
 - LOW VOLTAGE —
 - FIELD WIRING —
 - HIGH VOLTAGE —
 - LOW VOLTAGE —

A.O. SMITH MOTORS

AR120 MOTOR (B3240006)		AR090 MOTOR (B3240002)	
HIGH VOLTAGE (480V)	LOW VOLTAGE (240V)	HIGH VOLTAGE (480V)	LOW VOLTAGE (240V)
4 — 7 — 1 — L1	14 — 4 — 7 — 1 — L1	T4 — T7 — T1 — L1	T4 — P4 — T7 — T1 — L1
5 — 8 — 2 — L2	15 — 5 — 8 — 2 — L2	T5 — T8 — T2 — L2	T5 — P5 — T8 — T2 — L2
6 — 9 — 3 — L3	16 — 6 — 9 — 3 — L3	T6 — T9 — T3 — L3	T6 — P6 — T9 — T3 — L3
14 — INSULATE		P4 — INSULATE	
15 — INSULATE		P5 — INSULATE	
16 — INSULATE		P6 — INSULATE	

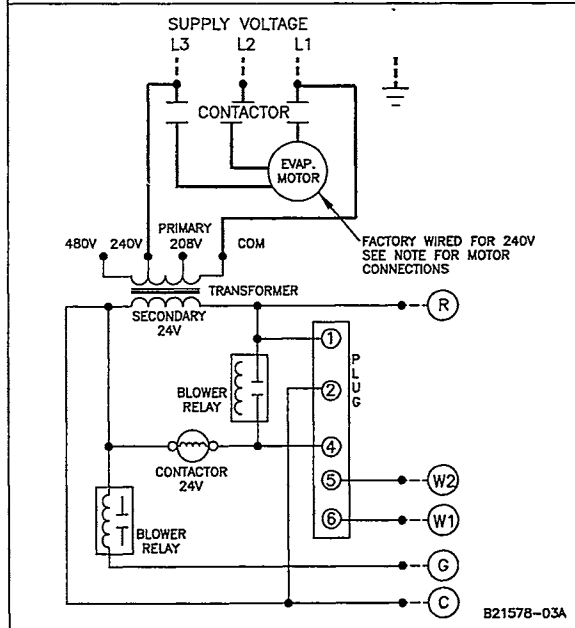

B21578-03A