



# REPAIR PARTS

---

## CKL90+ Model Condensing Units, Gray Color Models

CKL090-3L  
CKL090-4L  
CKL120-3L  
CKL120-4L

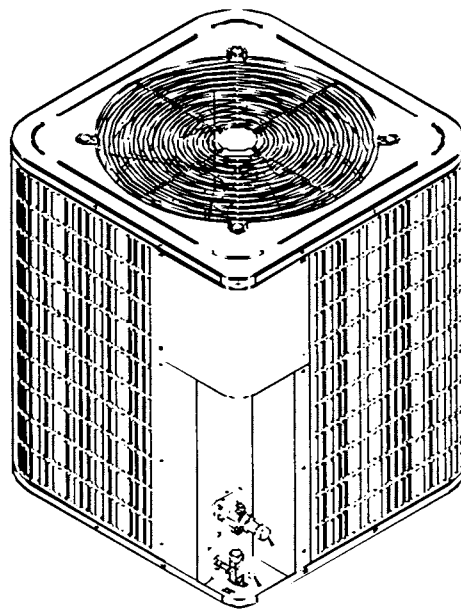

RP - 329  
October 2004

Made in the USA by:  
Goodman Manufacturing Company, L.P.  
2550 North Loop West, Suite 400  
Houston Texas 77092

This manual is to be used by qualified technicians only.

Copyright © 2004 Goodman Manufacturing Company, L.P.

## Important Information

---

Goodman Manufacturing Company, L.P. is not responsible for personal injury or property damage resulting from improper service. Review all service information before beginning repairs.

Warranty service must be performed by an authorized technician, using authorized factory parts. If service is required after the warranty expires, Goodman Manufacturing Company, L.P. also recommends contacting an authorized technician and using authorized factory parts.

For assistance within the U.S.A. contact:

Consumer Affairs Department  
Goodman Manufacturing Company, L.P.  
7401 Security Way  
Houston, Texas 77040  
877-254-4729-Telephone  
713-863-2382-Facsimile

For assistance outside the U.S.A. contact:

International Division  
Goodman Manufacturing Company, L.P.  
7401 Security Way  
Houston, Texas 77040  
713-861-2500-Telephone  
713-863-2382-Facsimile

# Index

Functional Parts List ..... 5  
Illustration and Parts ..... 6 - 7

*Views shown are for parts illustrations only, not servicing procedures.*

### Text Codes:

AR - As Required

NA - Not Available

NS - Not Shown

00000000 - See Note

QTY - Quantity Example (QTY 3) (If Quantity not shown, Quantity = 1)

M - Model Example (M1) (If M Code not shown, then part is used on all Models)

### Expanded Model Nomenclature:

Example
M1 - Model#1
M2 - Model#2
M3 - Model#3

This page left blank intentionally.

# Functional Parts

**Part**

**No: Description:**

---

B945673	CAPACITOR, 20/440
ZR108KCTF5950	COMPRESSOR, ZR108KC-TF5-250, OLD PN# B9266385 (M3)
ZR108KCTFD950	COMPRESSOR, ZR108KC-TFD-250, OLD PN# B9266384 (M4)
ZR84KCTF5950	COMPRESSOR, ZR84KC-TF5-250, OLD PN# B9266383 (M1)
ZR84KCTFD950	COMPRESSOR, ZR84KC-TFD-250, OLD PN# B9266382 (M2)
B1243749	CRANK CASE HEATER, 230V, 75 WATTS (M1, M3)
B1243732	CRANK CASE HEATER, 460V, 75 WATTS (M2, M4)
B1086768	FAN, BLADE, 30° PITCH, 26" DIAMETER
B1219228	FILTER DRIER, 5/8" X 3/4"
B1360721	HIGH PRESSURE SWITCH
B1360719	LOW PRESSURE SWITCH
B13400354	MOTOR, FAN, 208/230-60-1, 1 SPD, 1100 RPM, 1 HP (M1, M3)
B13400355	MOTOR, FAN, 460-60-1, 1 SPD, 1100 RPM, 1 HP (M2, M4)

### SPECIAL PARTS

IO-226	INSTALLATION AND OWNERS MANUAL
RP-329	REPAIR PARTS MANUAL
B260S8292	SPRAY PAINT, TOUCH-UP, DARK GRAY
PW-312A	WARRANTY

### Expanded Model Nomenclature

M1 - CKL090-3L
M2 - CKL090-4L
M3 - CKL120-3L
M4 - CKL120-4L

# CKL90+ Chassis

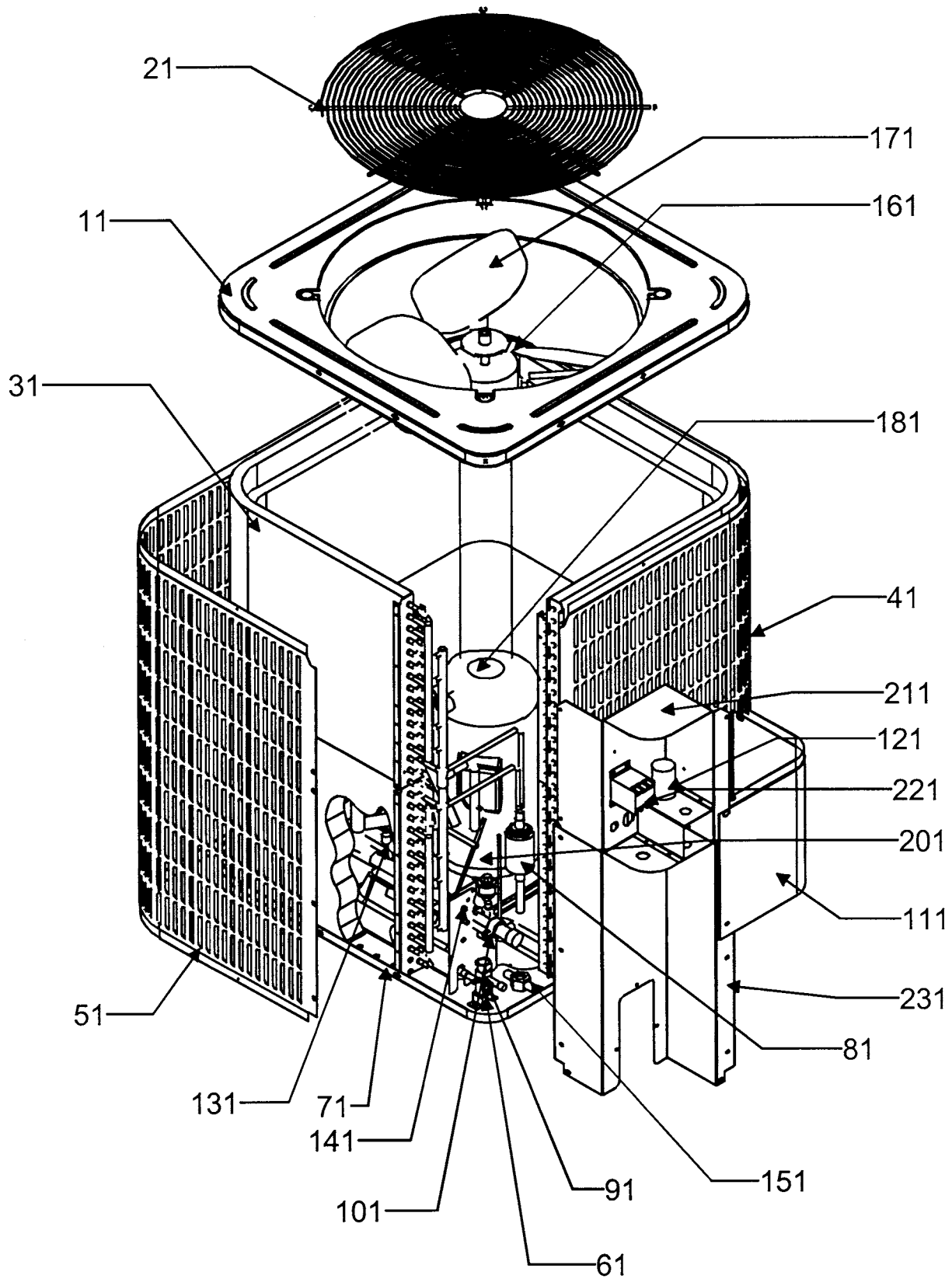

# CKL90+ Chassis

Ref. Part No:	No:	Description:	Ref. Part No:	No:	Description:
<i>Image 1:</i>					
11	4279400PDG	TOP PANEL, 35"			
21	B1376925	FAN GRILL GUARD, 26"			
31	1262116	CRATED COND. SERVICE COIL W/DRIER (M3, M4)			
31	1262117	CRATED COND. SERVICE COIL W/DRIER (M1, M2)			
41	4203404PDG	LOUVERED PANEL, 40", HAIRPIN SIDE			
51	4203405PDG	LOUVERED PANEL, 40", RETURN SIDE			
61	4223709	SUPPORT BRACKET			
71	4279100PDG	BOTTOM PAN, 35"			
81	B1219228	FILTER DRIER, 5/8" X 3/4"			
91	B1282573	VALVE BASE, LIQUID LINE, 5/8" X 5/8"			
101	B1282574	VALVE BASE, SUCTION LINE, 1 1/8" X 1 1/8"			
111	4223701PDG	CONTROL BOX COVER			
121	B945673	CAPACITOR, 20/440			
131	B1360719	LOW PRESSURE SWITCH			
141	B1360721	HIGH PRESSURE SWITCH			
151	B1372801	SIGHT GLASS			
161	B13400354	MOTOR, FAN, 208/230-60-1, 1 SPD, 1100 RPM, 1 HP (M1, M3)			
161	B13400355	MOTOR, FAN, 460-60-1, 1 SPD, 1100 RPM, 1 HP (M2, M4)			
171	B1086768	FAN, BLADE, 30° PITCH, 26" DIAMETER			
181	ZR108KCTF5950	COMPRESSOR, ZR108KC-TF5-250, OLD PN# B9266385 (M3)			
181	ZR108KCTFD950	COMPRESSOR, ZR108KC-TFD-250, OLD PN# B9266384 (M4)			
181	ZR84KCTF5950	COMPRESSOR, ZR84KC-TF5-250, OLD PN# B9266383 (M1)			
181	ZR84KCTFD950	COMPRESSOR, ZR84KC-TFD-250, OLD PN# B9266382 (M2)			
201	B1243749	CRANK CASE HEATER, 230V, 75 WATTS (M1, M3)			
201	B1243732	CRANK CASE HEATER, 460V, 75 WATTS (M2, M4)			
211	4287600	CONTROL BOX			
221	B1360335	CONTACTOR, 3 POLE, 40 AMP, 24 COIL			
231	4223700PDG	PANEL, ACCESS, 35"			
NS	B1339533	GROMMET, COMPRESSOR (QTY 4)			
NS	B260S8292	SPRAY PAINT, TOUCH-UP, DARK GRAY			

Expanded Model Nomenclature

- |                |
|----------------|
| M1 - CKL090-3L |
| M2 - CKL090-4L |
| M3 - CKL120-3L |
| M4 - CKL120-4L |

1

2

3