

# **INSTALLATION & OPERATING INSTRUCTIONS**

**For Use With Models:  
AH1826-1, AH2429-1,  
AH-1826-1FP, AH2429-1FP**

All information contained herein is subject to change without notice.

I0-164H

Goodman Manufacturing Company, L.P.  
2550 North Loop West, Suite 400, Houston, TX 77092  
[www.goodmanmfg.com](http://www.goodmanmfg.com)  
© 2003-2004 Goodman Manufacturing Company, L.P.

12/04

## INDEX

Introduction .....	2
Replacement Parts .....	2
Safety Instructions .....	2
Installation Procedure .....	2
Electrical Wiring .....	3
Evaporator Coil Connections .....	3
Condensate Drain Connections .....	4
Hot Water Connections .....	4
Purging the System .....	4
Air Filter Replacement .....	4
Pump Replacement .....	4
Secondary Check Valve .....	4
Common Problems & Solutions .....	4
Plumbing Requirements .....	5
Plumbing Requirements .....	6
for the Commonwealth of Massachusetts	
Wiring Diagram .....	8

## INTRODUCTION

### CHECKING PRODUCT RECEIVED

Upon receiving the unit, inspect it for damage from shipment. Claims for damage, either shipping or concealed, should be filed immediately with the shipping company. Check the unit model number, specifications, electrical characteristics and accessories to determine if they are correct. In the event an incorrect unit is shipped, it must be returned to the supplier and must NOT be installed. The manufacturer assumes no responsibility for installation of incorrectly shipped units.

### BEFORE BEGINNING INSTALLATION

Carefully read all instructions for the installation prior to installing unit. Make sure each step or procedure is understood and any special considerations are taken into account before starting installation. Assemble all tools, hardware and supplies needed to complete the installation. Some items may need to be purchased locally. Make sure everything needed to install air handler is on hand before starting. After deciding where to install unit, closely look the location over - both the inside and outside of home. Note any potential obstacles or problems that might be encountered as noted in this manual. Choose a more suitable location if necessary.

## REPLACEMENT PARTS

### ORDERING PARTS

When reporting shortages or damages, or ordering repair parts, give the complete unit model and serial numbers as stamped on the unit's nameplate. Replacement parts for this appliance are available through your contractor or local distributor. For the location of your nearest distributor consult the white business pages, the yellow page section of the local telephone book or contact:

SERVICE PARTS DEPARTMENT  
GOODMAN MANUFACTURING COMPANY, L.P.  
2550 NORTH LOOP WEST, SUITE 400  
HOUSTON, TEXAS 77092  
(713) 861 - 2500

## IMPORTANT SAFETY INSTRUCTIONS

### Recognize Safety Symbols, Words, and Labels

The following symbols and labels are used throughout this manual to indicate immediate or potential hazards. It is the owner's responsibility to read and comply with all safety information and instructions accompanying these symbols. Failure to heed safety information increases the risk of serious personal injury or death, property damage and/or product damage.

### **DANGER**

IMMEDIATE HAZARDS WHICH **WILL** RESULT IN PROPERTY DAMAGE, PRODUCT DAMAGE, SEVERE PERSONAL INJURY AND/OR DEATH.

### **WARNING**

HAZARDS OR UNSAFE PRACTICES **COULD** RESULT IN PROPERTY DAMAGE, PRODUCT DAMAGE, SEVERE PERSONAL INJURY AND/OR DEATH.

### **CAUTION**

HAZARDS OR UNSAFE PRACTICES WHICH **MAY** RESULT IN PROPERTY DAMAGE, PRODUCT DAMAGE, AND/OR PERSONAL INJURY.

 **DANGER**  
PELIGRO



**CARBON MONOXIDE POISONING HAZARD**

Special Warning for Installation of Furnace or Air Handling Units in Enclosed Areas such as Garages, Utility Rooms or Parking Areas

Carbon monoxide producing devices (such as an automobile, space heater, gas water heater, etc.) should not be operated in enclosed areas such as unventilated garages, utility rooms or parking areas because of the danger of carbon monoxide (CO) poisoning resulting from the exhaust emissions. If a furnace or air handler is installed in an enclosed area such as a garage, utility room or parking area and a carbon monoxide producing device is operated therein, there must be adequate, direct outside ventilation.

This ventilation is necessary to avoid the danger of CO poisoning which can occur if a carbon monoxide producing device continues to operate in the enclosed area. Carbon monoxide emissions can be (re)circulated throughout the structure if the furnace or air handler is operating in any mode.

CO can cause serious illness including permanent brain damage or death.

B10259-216

### **WARNING**

DO NOT CONNECT TO OR USE IN CONJUNCTION WITH THIS UNIT ANY DEVICES FOR THE PURPOSE OF SAVING ENERGY OR INCREASING OPERATING EFFICIENCIES, WHICH HAVE NOT BEEN TESTED AND APPROVED BY GOODMAN AND DESIGN CERTIFIED FOR USE WITH THIS UNIT. SERIOUS DAMAGE, REDUCED UNIT PERFORMANCE AND HAZARDOUS CONDITIONS MAY RESULT FROM THE USE OF DEVICES WHICH HAVE NOT BEEN APPROVED OR CERTIFIED BY GOODMAN.

## WARNING

HEATING UNIT SHOULD NOT BE UTILIZED WITHOUT REASONABLE, ROUTINE, INSPECTION, MAINTENANCE AND SUPERVISION. IF THE BUILDING IN WHICH ANY SUCH DEVICE IS LOCATED WILL BE VACANT, CARE SHOULD BE TAKEN THAT SUCH DEVICE IS ROUTINELY INSPECTED, MAINTAINED AND MONITORED. IN THE EVENT THAT THE BUILDING MAY BE EXPOSED TO FREEZING TEMPERATURES AND WILL BE VACANT, ALL WATER-BEARING PIPES SHOULD BE DRAINED, THE BUILDING SHOULD BE PROPERLY WINTERIZED, AND THE WATER SOURCE CLOSED. IN THE EVENT THAT THE BUILDING MAY BE EXPOSED TO FREEZING TEMPERATURES AND WILL BE VACANT, ANY HYDRONIC COIL UNITS SHOULD BE DRAINED AS WELL AND, IN SUCH CASE, ALTERNATIVE HEAT SOURCES SHOULD BE UTILIZED.

## CAUTION

FOR UNITS SHIPPED WITH THE FREEZE PROTECTION OPTION, FREEZE PROTECTION WILL NOT WORK UNLESS THERE IS POWER TO THE UNIT.

## INSTALLATION PROCEDURE

This product is designed and manufactured to permit installation in accordance with National Codes. It is the installer's responsibility to install the product in accordance with National Codes and/or prevailing local codes and regulations. If screws or holes must be drilled into the fan coil cabinet, check carefully to insure that no damage is done to internal components. This unit is equipped with a blower safety switch, which will not allow the blower to function unless the door is in place. Use a low temperature, non-lead solder on all water line copper joints.

Perform pre-installation check points before attempting any installation. The following check points should be considered:

- Structural strength of supporting members
- Clearances and provision for servicing
- Power supply and wiring
- Air duct connections
- Drain facilities and connections

## WARNING

IF A BACK FLOW PREVENTER IS INSTALLED IN THE SYSTEM, AN EXPANSION TANK IS NECESSARY.

## WARNING

THE HOT WATER COIL AND ALL WATER LINES MUST BE PURGED OF AIR BEFORE THE HOT WATER PUMP CAN BE ENERGIZED. FAILURE TO PURGE THE WATER SYSTEM OF AIR CAN RESULT IN DAMAGE TO THE PUMP.

## CAUTION

INSULATE AND PROTECT ALL WATER PIPING AS NECESSARY TO PREVENT FREEZING. FROZEN OR BROKEN WATER PIPES MAY CAUSE DAMAGE TO THE UNIT AND ARE NOT COVERED UNDER WARRANTY.

## UNIT INSTALLATION

**NOTE:** For installation in the Commonwealth of Massachusetts refer to the schematic plumbing diagrams in Figure 3 and 4.

This unit must be installed in a vertical position with the return at the bottom and the plenum at the top. The return may be ducted through the bottom of the unit by removing the drain access panel and filter, then reattaching the lower access panel. The clearance to combustibles (which includes the cabinet, plenum and all connecting ductwork) is zero inches. However, approximately 20 inches of clearance must be provided at the front of the unit to allow access to internal components. Several installations are possible in this configuration:

- The unit can be hung on a closet wall by using a bracket made by the installer or by purchasing a bracket made by the fan coil manufacturer. To prevent the transfer of normal operational sound through the wall, use a sound deadening or isolating material.
- The unit can be installed on a platform in a closet. Screws or nails must be used to secure the unit in place. The platform must provide ample clearance for drain lines that exit the unit from the bottom.
- The fan coil can be installed in a partition wall as shown in Figure 1. A louvered wall panel (made by the fan coil manufacturer) must be used with this type of installation and the lower access panel must be removed. The fan coil is installed before the drywall and the louvered panel is installed with screws or nails once the drywall is in place.

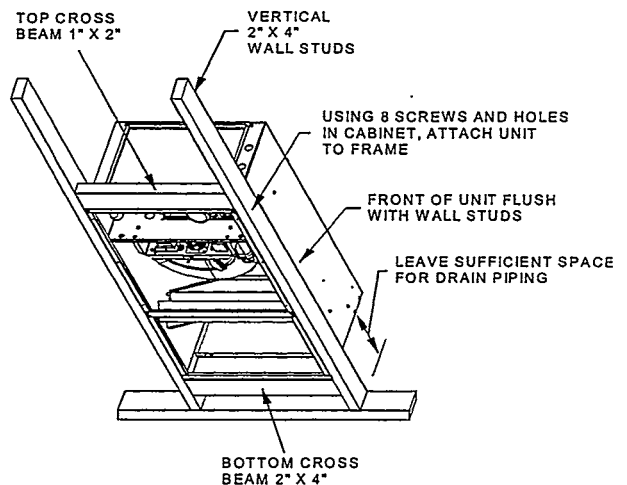

FIGURE 1

## AIR DUCT INSTALLATION NOTES

If a ducted return is used, it must have the same free area as the opening on the unit. If a non-ducted return is used, local or national codes may restrict the unit installation to single story residences only.

## ELECTRICAL WIRING

All information needed to connect the 120VAC supply and the 24VAC-control wiring is supplied with the unit (see unit wiring diagram). Two knockouts are located at the top of the unit for connection of power and control wiring. Since this unit is supplied with a 24 volt Class 2 transformer, a thermostat with isolating contacts must be used when connecting other add-on equipment using a Class 2 transformer.

## EVAPORATOR COIL CONNECTIONS

This fan coil uses a factory installed fixed orifice piston to meter the refrigerant to the evaporator. This allows the fan coil to be matched to a heat pump or a conventional condensing unit. The evaporator has a trace gas charge that **MUST** be released before installation.

## CONDENSATE DRAIN CONNECTIONS

A minimum trap of 1-1/2" must be in the drain line so that there is proper drainage. The drain lines must be installed to slope away from the fan coil.

## HOT WATER CONNECTIONS

The connections to the hot water coil are 3/4" (7/8" O.D.) copper tubing. The hot water inlet is located on the top right of the unit (a label on the unit clearly identifies the correct connection). All piping connecting the fan coil to the house water system should be 3/4" (7/8" O.D.) copper tubing. This size tubing will prevent loss of head pressure. The total length of piping used to connect the fan coil to the water heater should not exceed 200 feet. Use "T" fittings at the water heater to connect into the house water system. These "T" fittings must be installed on the vertical hot and cold supply lines of the water heater as shown in Figure 2. The connections from the fan coil unit are made to the horizontal connection of the T" fittings. This will allow air to be purged from the system when water is used in the home. Between the fan coil and water heater connections, two valves (provided by the installer) must be installed to permit the purging of air in the system and also to allow the hot water coil in the unit to be separated from the house water system during servicing.

## PURGING THE SYSTEM



### DANGER

140-DEGREE WATER CAN CAUSE FIRST DEGREE BURNS. WE REQUIRE THE INSTALLATION OF A WATER-TEMPERING VALVE TO SUPPLY LOWER TEMPERATURE WATER TO THE FIXTURES IN THE HOUSE. USE A WATTS N170L SERIES OR EQUIVALENT.

1. Open hot water faucet (to vent air) and allow water heater to fill with water. Close faucet when water heater tank is full and all air has been purged.
2. Ignite water heater. Set thermostat on water heater to 140 degrees.
3. As shown in Figure 2, close the valve on the hot water supply from the water heater ("A") and open the valve on the cold water return to the water heater ("B"). Then open the air bleed valve in the fan coil. Use bucket or hose to discard water during purging process at air bleed valve. Purge air completely from lines.
4. Once air is purged, close return valve ("B") and open supply valve ("A"). Purge the coil and lines of air completely.
5. After air is purged from the system and filled with water, open the return valve ("B") and the supply valve ("A"). Then close the air bleed valve in the fan coil.
6. Slowly remove the indicator plug in the middle of the nameplate. Allow the air to purge from the pump until water appears. While air is venting, gently turn shaft and move it in and out with a small flat blade screwdriver. Protect the terminal box from getting wet. After air has been vented, install and re-tighten the plug.
7. Apply power to the fan coil and set the room thermostat on heat. (The fan coil unit will not operate unless the door safety switch is activated.) Raise the temperature setting to activate the circulating pump.
8. Check the pump to insure proper operation. The water inlet of the unit should be hot if the water temperature in the water heater has reached the set point. If water is not being circulated through the coil, but the pump is running, then open the air bleed valve in the unit and purge any air left in the system.

9. Adjust the water heater thermostat so that the water temperature entering the hot water coil is 140 degrees. This is done with the unit energized and operating long enough for all temperatures to stabilize.

## AIR FILTER REPLACEMENT

An air filter can restrict the flow of air to the fan coil if it is not cleaned or replaced periodically. When replacing the air filter, always replace with the same type and size as originally furnished with the unit. Never operate comfort equipment without filter(s).

## PUMP REPLACEMENT

1. Disconnect electrical power to the unit before servicing.
2. Remove access door to reveal pump. Close supply valve ("A") and return valve ("B"). Open the air bleed valve to depressurize the system and drain water.
3. Remove the metal pump housing by loosening the four screws on the pump. **DO NOT UNSOLDER PUMP.**
4. Replace with new pump housing assembly and reconnect components to pump. Before assembling, make sure that the rubber o-ring is in place on the pump housing.

Purge the system of air as described earlier and reconnect the electrical power.

## SECONDARY CHECK VALVE

A secondary check valve is to be installed on the inlet side of the unit. (Install the check valve as close to water heater as is feasible.) A spring loaded Watts Regulator 600 series 3/4" npt check valve is supplied with your unit for this purpose and may be installed in a vertical or horizontal position. Install the check valve as close to the water heater as is feasible. On AH units, the check valve is located behind the front panel and is secured to the hydronic tubing manifold with 2 wire ties. See Figure 2 for schematic diagram of secondary check valve.

**NOTE:** In the rare case that thermal siphoning occurs with secondary check valve installation, it is recommended that a solenoid operated valve be installed. See Figure 2 for schematic diagram of solenoid valve.

## COMMON PROBLEMS & SOLUTIONS

- **NOISY PUMP:**
  - System may not be totally purged of air. Purge the system again as described earlier.
- **T & P VALVE ON WATER HEATER WEEPS:**
  - This normally occurs when a backflow preventer has been installed in the cold water line supplying the water heater. An expansion tank may be necessary to correct the problem. Contact a qualified plumbing professional for assistance.
- **HOT WATER IS CIRCULATING THROUGH THE HEATING COIL DURING THE COOLING CYCLE:**
  - The check valve may be stuck open and allowing hot water to circulate through the coil.
- **LITTLE OR NO HEAT FROM WATER COIL:**
  - A. Purge system. Air may still be in water lines.
  - B. The inlet and outlet connections may be reversed at the fan coil.
  - C. Water heater thermostat is not set at proper temperature.
  - D. Water heater thermostat is not calibrated.
  - E. The dip tube in the water heater may not be installed correctly or may be restricted.
  - F. Look for restriction in heating system from water heater to fan coil. Because some water heaters are supplied with check valves, remove any extra check valves except for the one supplied with the fan coil.
  - G. The air handler is undersized for the space being heated.
  - H. Water heater is undersized.

# PLUMBING REQUIREMENTS

SEE FIGURES 3 & 4 IF UNIT IS INSTALLED IN THE COMMONWEALTH OF MASSACHUSETTS

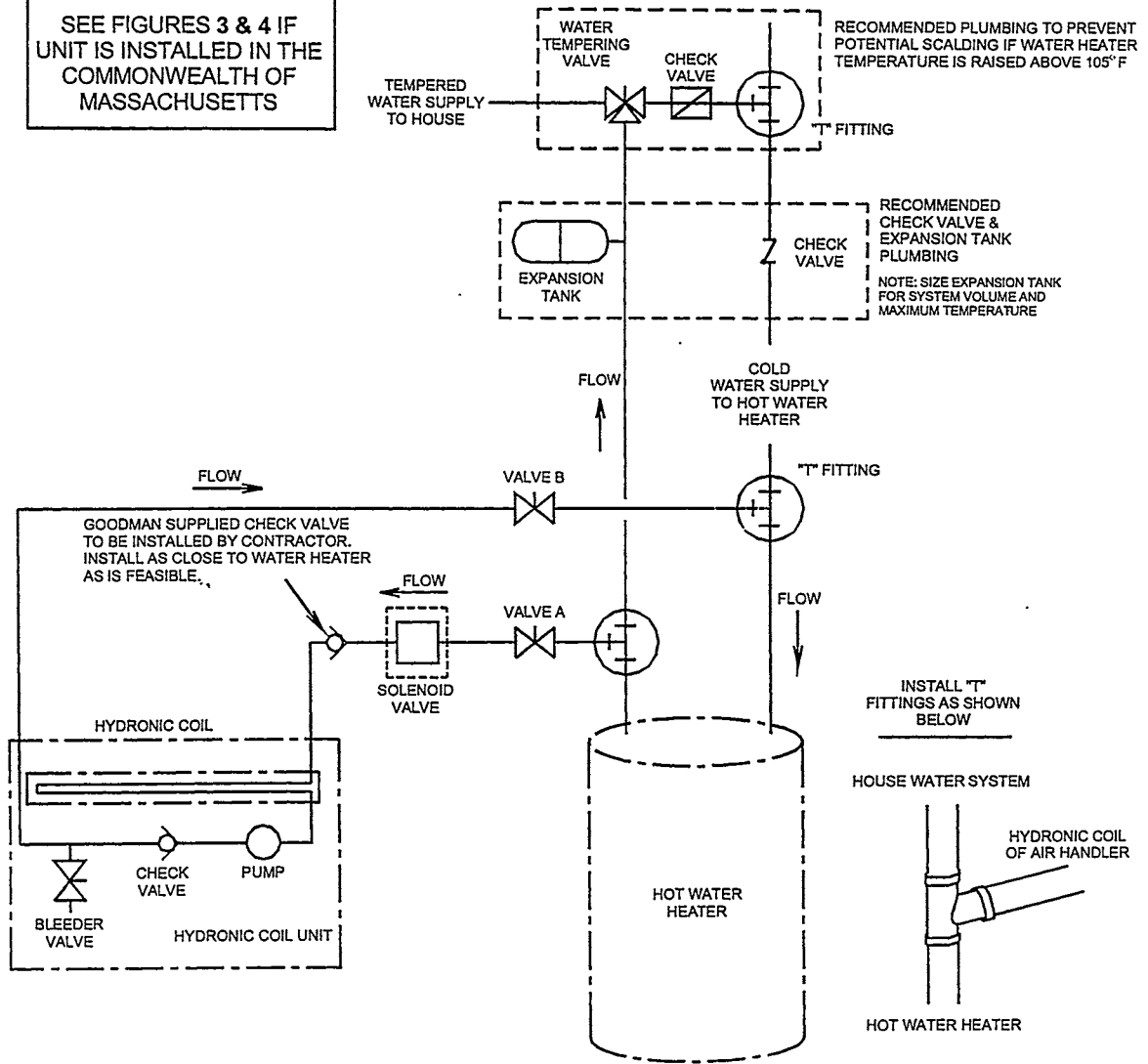
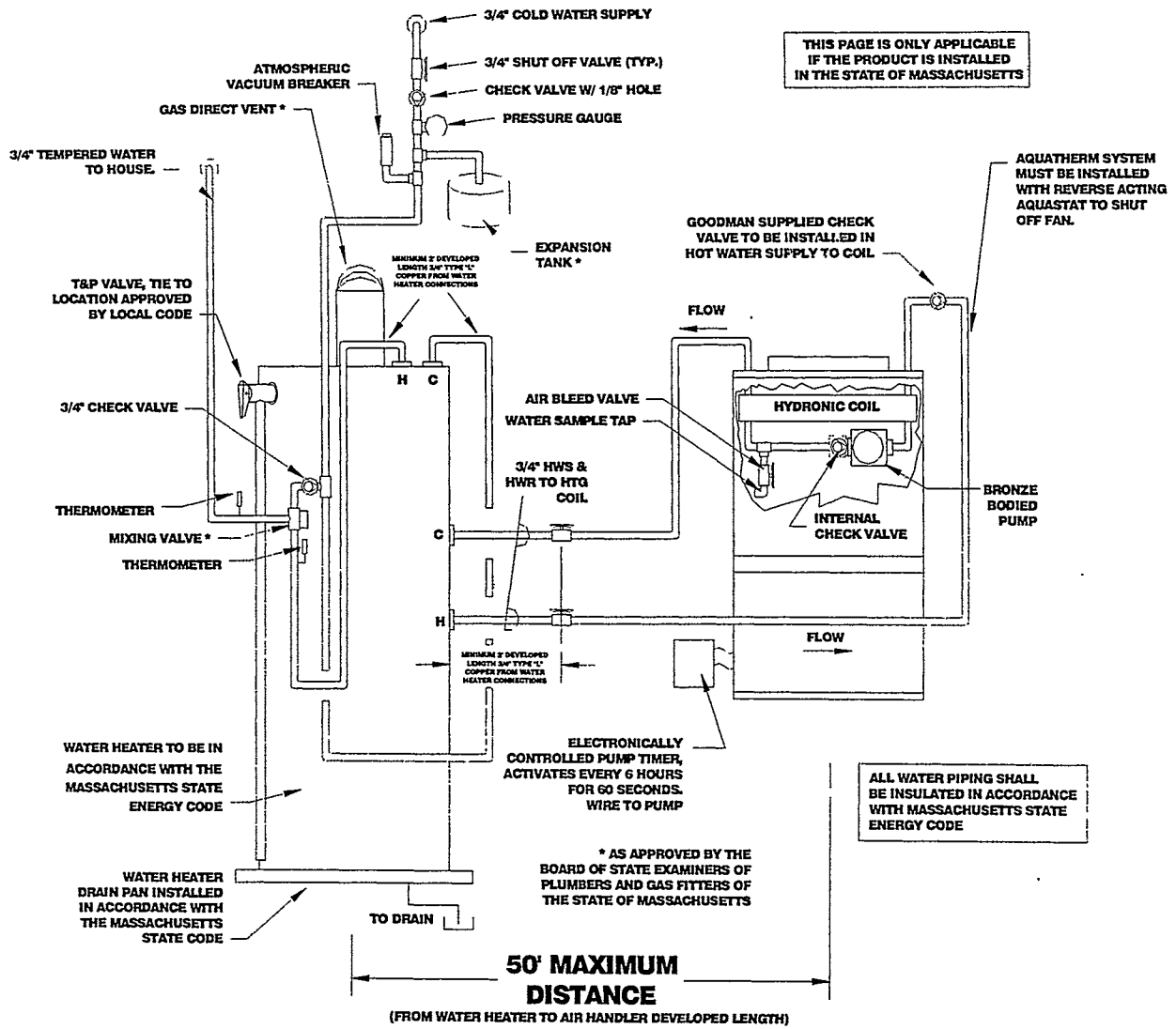
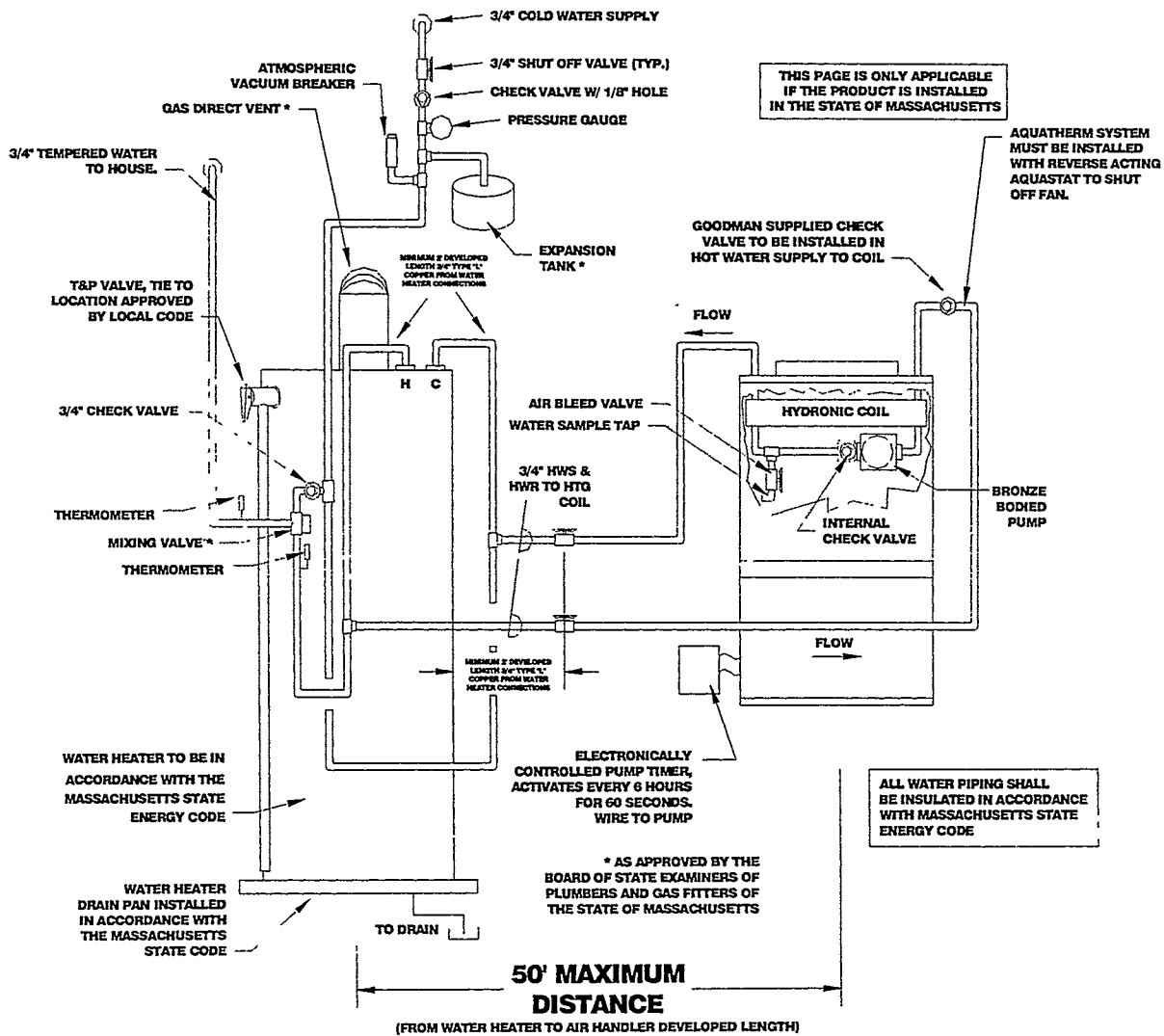

FIGURE 2

**PLUMBING REQUIREMENTS  
PER THE COMMONWEALTH OF MASSACHUSETTS  
BOARD OF STATE EXAMINERS OF PLUMBERS AND GAS FITTERS**



**PLUMBING REQUIREMENTS  
PER THE COMMONWEALTH OF MASSACHUSETTS  
BOARD OF STATE EXAMINERS OF PLUMBERS AND GAS FITTERS**



# WIRING DIAGRAM

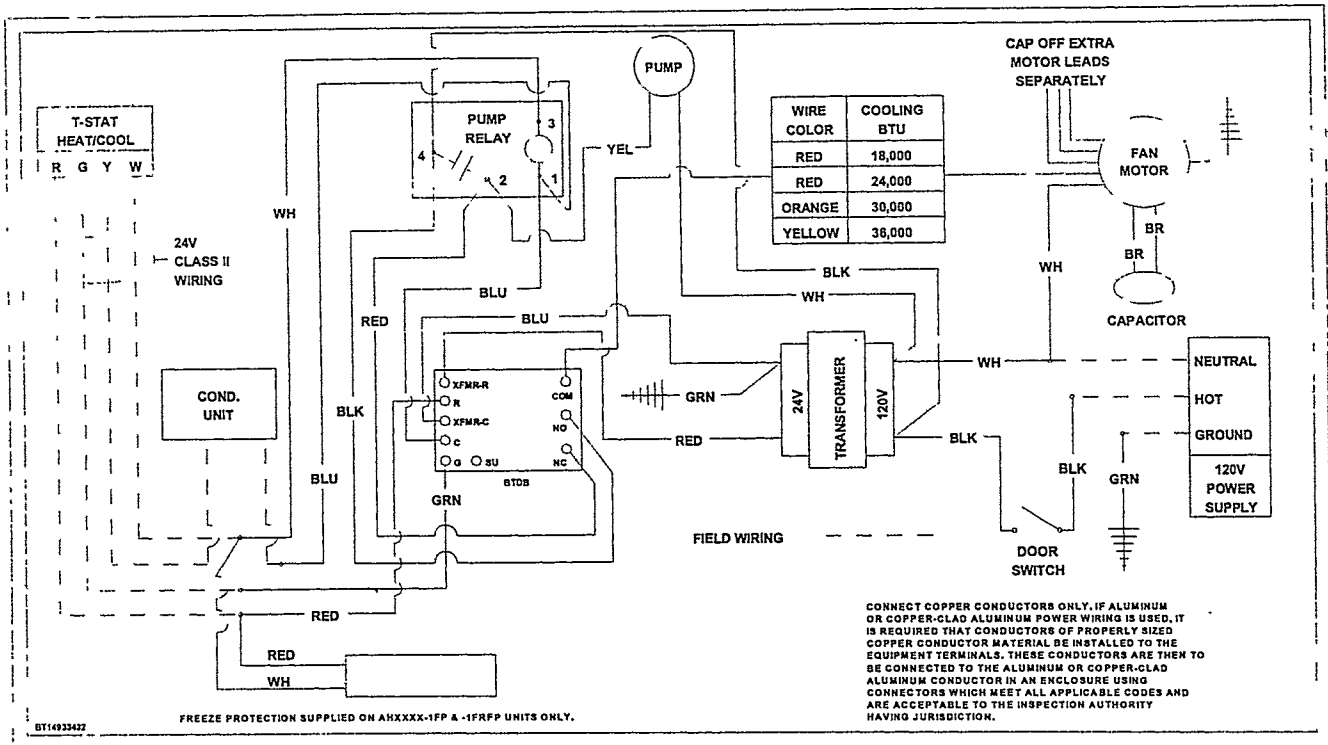

## Quality Makes the Difference!

All of our systems are designed and manufactured with the same high quality standards regardless of size or efficiency. We have designed these units to significantly reduce the most frequent causes of product failure. They are simple to service and forgiving to operate. We use quality materials and components. Finally, every unit is run tested before it leaves the factory. That's why we know. . . **There's No Better Quality.**

Visit our website at [www.goodmanmfg.com](http://www.goodmanmfg.com) for information on:

- Goodman products
- Warranties
- Customer Services
- Parts
- Contractor Programs and Training
- Financing Options

© 2003-2004 Goodman Manufacturing Company, L.P.