

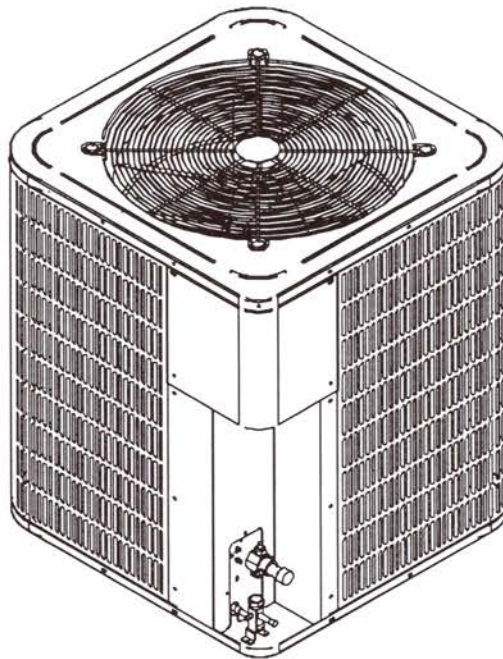

REPAIR PARTS

CPLE090 - 120 Light Commercial Condensing Units

CPLE090-3
CPLE090-4
CPLE120-3
CPLE120-4



This manual is to be used by qualified technicians on

Made in the USA by:
Goodman Manufacturing Company, L.P.
2550 North Loop West, Suite 400
Houston Texas 77092

RP - 294A
October 2004

This manual replaces RP-294.

Copyright © 2004 Goodman Manufacturing Company, L.P.

Important Information

Goodman Manufacturing Company, L.P. is not responsible for personal injury or property damage resulting from improper service. Review all service information before beginning repairs.

Warranty service must be performed by an authorized technician, using authorized factory parts. If service is required after the warranty expires, Goodman Manufacturing Company, L.P. also recommends contacting an authorized technician and using authorized factory parts.

For assistance within the U.S.A. contact:

Consumer Affairs Department
Goodman Manufacturing Company, L.P.
7401 Security Way
Houston, Texas 77040
877-254-4729-Telephone
713-863-2382-Facsimile

For assistance outside the U.S.A. contact:

International Division
Goodman Manufacturing Company, L.P.
7401 Security Way
Houston, Texas 77040
713-861-2500-Telephone
713-863-2382-Facsimile

Index

Functional Parts List	5
Illustration and Parts	6 - 7

Views shown are for parts illustrations only, not servicing procedures.

Revision A: Updates service coil part numbers.

Text Codes:

AR - As Required

NA - Not Available

NS - Not Shown

00000000 - See Note

QTY - Quantity Example (QTY 3) (If Quantity not shown, Quantity = 1)

M - Model Example (M1) (If M Code not shown, then part is used on all Models)

Expanded Model Nomenclature:

Example

M1 - Model#1

M2 - Model#2

M3 - Model#3

This page left blank intentionally.

Functional Parts

Part

No: Description:

B945673 CAPACITOR, 20/440
ZR108KCTF5950 COMPRESSOR, ZR108KC-TF5-250, OLD PN# B9266385 (M3)
ZR108KCTFD950 COMPRESSOR, ZR108KC-TFD-250, OLD PN# B9266384 (M4)
ZR84KCTF5950 COMPRESSOR, ZR84KC-TF5-250, OLD PN# B9266383 (M1)
ZR84KCTFD950 COMPRESSOR, ZR84KC-TFD-250, OLD PN# B9266382 (M2)
B1243749 CRANKCASE HEATER, 208/230-50/60, 75 WATTS (M1, M3)
B1243732 CRANKCASE HEATER, 460-50/60, 75 WATTS (M2, M4)
1262234 CRATED COND. SERVICE COIL W/DRIER (M3, M4)
1262233 CRATED COND. SERVICE COIL W/DRIER (M1, M2)
B1226008S DEFROST CONTROL, TIMER
B1370803 DEFROST THERMOSTAT
B1219227 FILTER DRIER, STEEL, BI-FLOW, 5/8" X 5/8"
B1360721 HIGH PRESSURE SWITCH
B1360719 LOW PRESSURE SWITCH
B13400354 MOTOR, FAN, 208/230-60-1, 1 SPD, 1100 RPM, 1 HP (M1, M3)
B13400355 MOTOR, FAN, 460-60-1, 1 SPD, 1100 RPM, 1 HP (M2, M4)
B1370751 RELAY
B1227312 VALVE, REVERSING (M1, M2)
B1227313 VALVE, REVERSING (M3, M4)

SPECIAL PARTS

IO-229 INSTALLATION AND OWNERS MANUAL
RP-294 REPAIR PARTS MANUAL
SS-361 SPECIFICATION SHEET
B260S8291 SPRAY PAINT, TOUCH UP, BAHAMA BEIGE

Expanded Model Nomenclature

M1 - CPLE090-3
M2 - CPLE090-4
M3 - CPLE120-3
M4 - CPLE120-4

Chassis

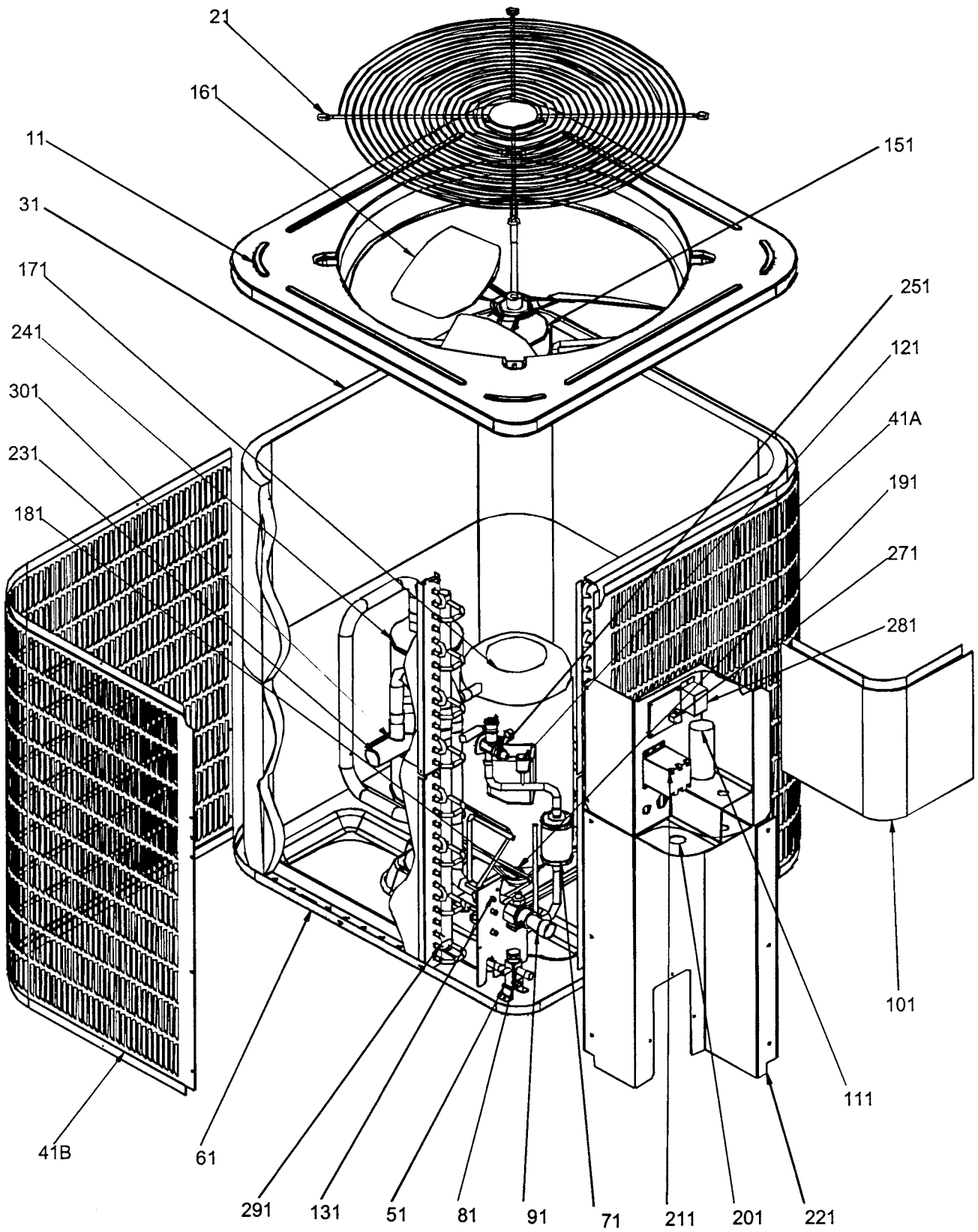

Chassis

Ref. Part

No: No:

Description:

Ref. Part

No: No:

Description:

Image 1:

11	4279400P	TOP PANEL, 35"
21	B1376925	FAN GRILL GUARD
31	1262233	CRATED COND. SERVICE COIL W/DRIER (M1, M2)
31	1262234	CRATED COND. SERVICE COIL W/DRIER (M3, M4)
41	4203404P	PANEL, LOUVER, 40.0", HAIRPIN SIDE
41	4203405P	PANEL, LOUVER, 40.0", RETURN SIDE
51	4223709	SUPPORT BRACKET
61	4279100P	PAN, BOTTOM, 35.0"
71	B1219227	FILTER DRIER, STEEL, BI-FLOW, 5/8" X 5/8"
81	B1282573	BASE VALVE, LIQUID LINE, 5/8" X 5/8"
91	B1282574	BASE VALVE, SUCTION LINE, 1 1/8" X 1 1/8"
101	4223701P	CONTROL BOX COVER
111	B945673	CAPACITOR, 20/440
121	B1360719	LOW PRESSURE SWITCH
131	B1360721	HIGH PRESSURE SWITCH
151	B13400354	MOTOR, FAN, 208/230-60-1, 1 SPD, 1100 RPM, 1 HP (M1, M3)
151	B13400355	MOTOR, FAN, 460-60-1, 1 SPD, 1100 RPM, 1 HP (M2, M4)
161	B1086768	FAN, 3 BLADE, 30°PITCH, 26" DIA.
171	ZR108KCTF5950	COMPRESSOR, ZR108KC-TF5-250, OLD PN# B9266385 (M3)
171	ZR108KCTFD950	COMPRESSOR, ZR108KC-TFD-250, OLD PN# B9266384 (M4)
171	ZR84KCTF5950	COMPRESSOR, ZR84KC-TF5-250, OLD PN# B9266383 (M1)
171	ZR84KCTFD950	COMPRESSOR, ZR84KC-TFD-250, OLD PN# B9266382 (M2)
181	B1339533	GROMMET, COMPRESSOR (QTY 4)
191	B1243749	CRANKCASE HEATER, 208/230-50/60, 75 WATTS (M1, M3)
191	B1243732	CRANKCASE HEATER, 460-50/60, 75 WATTS (M2, M4)
201	4287600	CONTROL BOX
211	B1360335	CONTACTOR, 3 POLE, 240/277, 24V
221	42237009P	PANEL, ACCESS, LOWER, 40.0"
231	B1227312	VALVE, REVERSING (M1, M2)
231	B1227313	VALVE, REVERSING (M3, M4)
241	B1226212	ACCUMULATOR
251	B3232211	EXPANSION VALVE/TUBING ASSEMBLY (M1, M2)
251	B3232212	EXPANSION VALVE/TUBING ASSEMBLY (M3, M4)
271	B1226008S	DEFROST CONTROL, TIMER
281	B1370751	RELAY
291	B1370803	DEFROST THERMOSTAT
301	B1225020	SOLENOID CORD
NS	B1376926	MOTOR MOUNTING BRACKET
NS	B1393025	PLASTIC GRILL FASTENER (QTY 4)
NS	B1372801	SIGHT GLASS
NS	B260S8291	SPRAY PAINT, TOUCH UP, BAHAMA BEIGE

Expanded Model Nomenclature

M1 - CPLE090-3
M2 - CPLE090-4
M3 - CPLE120-3
M4 - CPLE120-4