

ACHP SERIES
10-12 SEER

Ceiling-Mount Air Handler
With Hydronic Heating
Coils

1½ to 3 Ton

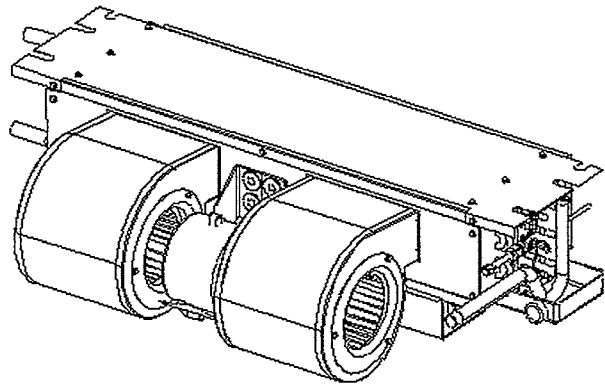

Standard Features

- Galvanized-steel construction
- Factory-wired circulating pump with checkvalve and boiler drain
- Factory-installed hydronic coils
- Direct-drive, resilient-mounted, 2-speed motor
- Equipped with check flowrater for heat pump application
- Primary/secondary drain connection on high-temperature plastic drain pan (3-ton units have painted galvanized-steel drain pans)
- High-efficiency evaporator coil
- Quiet operation
- Easy service access
- Steel blower wheels
- ARI Rated Match System

Accessories

- Heat pump shut-off relay (HPSK-01)
 - Ceiling Access Panels
 - CAP-1 or 1L* fits ACHP18 & 24
 - CAP-2 or 2L* fits ACHP30
- *Louvered



PRODUCT SPECIFICATIONS

Performance Ratings

Model	Capacity Cooling Nominal BTUH	Capacity Heating Entering Water Temp °F		
		120	140	180
ACHP1819-1	18,000	13,150	18,400	28,500
ACHP2423-1	24,000	16,450	23,000	35,600
ACHP3028-1	30,000	19,500	27,300	42,300
ACHP3632-1	36,000	23,000	32,000	49,600

Electrical Data

Model	Volt	Min Volt	Max Volt	Minimum Ampacity	Maximum Overcurrent Protection	Blower Motor		Circulator Motor	
						FLA	HP	FLA	HP
ACHP1819-1	115	103	126	2.68	15 A	1.55	1/8	0.74	1/25
ACHP2423-1	115	103	126	8.24	15 A	6.00	1/3	0.74	1/25
ACHP3028-1	115	103	126	8.24	15 A	6.00	1/3	0.74	1/25
ACHP3632-1	115	103	126	5.62	15 A	3.90	1/2	0.74	1/25

Blower Performance (Wet Coil)

Model	Motor Speed	CFM Delivered Against External Static Pressure				
		0.1	0.2	0.3	0.4	0.5
ACHP1819-1	Low	607	568	507	452	389
	High	669	623	562	500	422
ACHP2423-1	Low	761	707	654	596	532
	High	815	769	703	650	592
ACHP3028-1	Low	1,001	940	878	812	749
	High	1,090	1,028	961	891	837
ACHP3632-1	Low	969	928	880	824	756
	High	1,256	1,181	1,117	1,059	1,037

Dimensions

MODEL	A	B	C	D
ACHP1819-1	40 1/4	37 1/4	34-11/16	30
ACHP2423-1	40 1/4	37 1/4	34-11/16	30
ACHP3028-1	46 1/4	43 1/4	40-11/16	36
ACHP3632-1	58	55	52 1/2	47 3/4

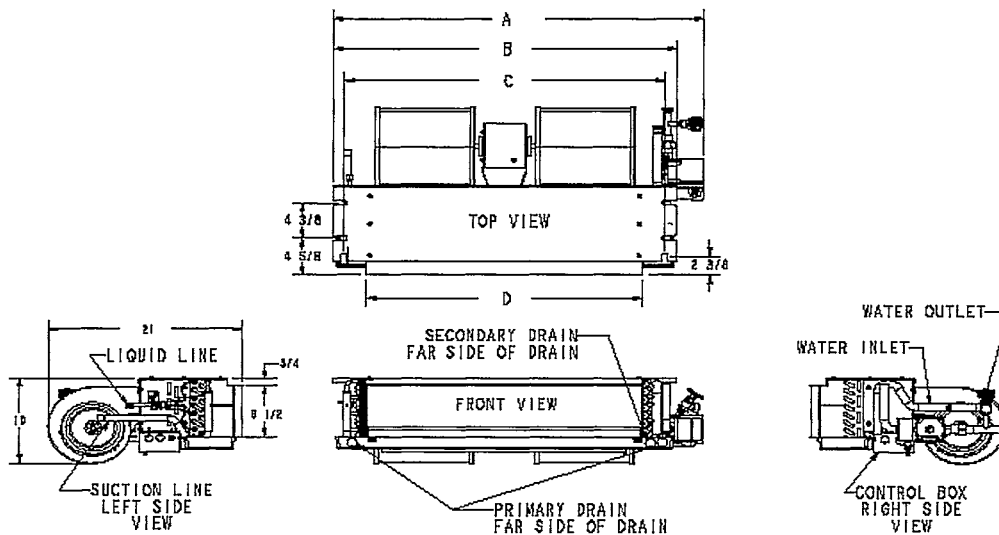

Janitrol[®]
SINCE 1890
air conditioning & heating

Goodman[®]
Air Conditioning & Heating

GMC[®]
Air Conditioning & Heating

Goodman Manufacturing Company, L.P., reserves the right to discontinue, or change at any time, specifications or designs without notice or without incurring obligations.
Copyright © 2003 Goodman Manufacturing Company, L.P. • Houston, Texas • Printed in the USA. • Goodman products are made proudly in the USA.