

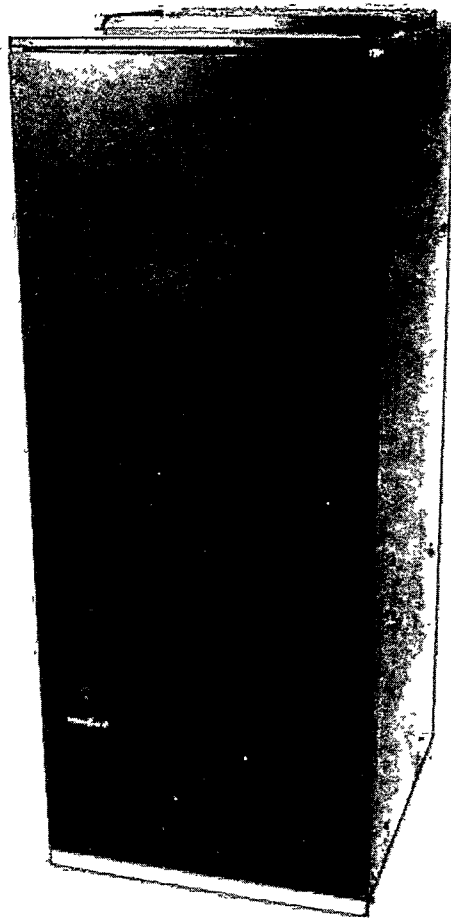

**INSTALLATION & OPERATING
INSTRUCTIONS FOR
ARUF, ARPF, ARPT and AEPT
SERIES AIR HANDLER**



Made in the USA by:

Goodman Manufacturing Company, L.P.
2550 North Loop West, Suite 400 - Houston, Texas 77092
www.goodmanmfg.com or www.amana-hac.com
© 2003-2004 Goodman Manufacturing Company, L.P.

08/04

IO-230F

INDEX

INTRODUCTION	2
REPLACEMENT PARTS	2
SAFETY INSTRUCTIONS	2
WARNINGS	2
MODEL IDENTIFICATION	3
PRODUCT DESCRIPTION	3
UNIT INSPECTION	4
ELECTRIC HEAT	4
HKR INSTALLATION	5
LOCATION	5
DUCTWORK	5
ELECTRICAL SUPPLY WIRE AND MOP	5
REFRIGERANT LINES	6
AEPT MOTOR ORIENTATION	8
CONVERSION TO DOWNFLOW	8
CONVERSION TO HORIZONTAL	9
CONDENSATE REMOVAL	9
ACHIEVING 2% LOW LEAKAGE RATE	10
ARUF/ARPF MOTOR	10
AEPT MOTOR	10
THERMOSTAT WIRING DIAGRAMS	11
THERMOSTATS	13

INTRODUCTION

Checking Product Received

Upon receiving the product, inspect it for damage from shipment. Claims for damage, either shipping or concealed, should be filed immediately with the shipping company. Check the product to determine if it is correct. In the event an incorrect product is shipped, it must be returned to the supplier and must NOT be installed. The manufacturer assumes no responsibility for installation of incorrectly shipped products.

Before Beginning Installation

Carefully read all instructions for the installation prior to installing product. Make sure each step or procedure is understood and any special considerations are taken into account before starting installation. Assemble all tools, hardware and supplies needed to complete the installation. Some items may need to be purchased locally. Make sure everything needed to install the product is on hand before starting.

REPLACEMENT PARTS

Ordering Parts

When reporting shortages or damages, or ordering repair parts, give the complete product model and serial numbers as stamped on the product. Replacement parts for this product are available through your contractor or local distributor. For the location of your nearest distributor consult the white business pages, the yellow page section of the local telephone book, or contact the following:

SERVICE PARTS DEPARTMENT
GOODMAN MANUFACTURING COMPANY, L.P.
2550 NORTH LOOP WEST, SUITE 400
HOUSTON, TEXAS 77092
(713) 861 - 2500

IMPORTANT SAFETY INSTRUCTIONS

Recognize Safety Symbols, Words, and Labels

The following symbols and labels are used throughout this manual to indicate immediate or potential hazards. It is the owner's responsibility to read and comply with all safety information and instructions accompanying these symbols. Failure to heed safety information increases the risk of serious personal injury or death, property damage and/or product damage.

DANGER

IMMEDIATE HAZARDS WHICH **WILL** RESULT IN PROPERTY DAMAGE, PRODUCT DAMAGE, SEVERE PERSONAL INJURY OR DEATH.

WARNING

HAZARDS OR UNSAFE PRACTICES **COULD** RESULT IN PROPERTY DAMAGE, PRODUCT DAMAGE, SEVERE PERSONAL INJURY OR DEATH.

CAUTION

HAZARDS OR UNSAFE PRACTICES WHICH **MAY** RESULT IN PROPERTY DAMAGE, PRODUCT DAMAGE, PERSONAL INJURY OR DEATH.

WARNING

THE UNIT **MUST** HAVE AN UNINTERRUPTED, UNBROKEN ELECTRICAL GROUND TO MINIMIZE THE POSSIBILITY OF PERSONAL INJURY IF AN ELECTRICAL FAULT SHOULD OCCUR. THE ELECTRICAL GROUND CIRCUIT MAY CONSIST OF AN APPROPRIATELY SIZED ELECTRICAL WIRE CONNECTING THE GROUND LUG IN THE UNIT CONTROL BOX TO THE BUILDING ELECTRICAL SERVICE PANEL. OTHER METHODS OF GROUNDING ARE PERMITTED IF PERFORMED IN ACCORDANCE WITH THE "NATIONAL ELECTRIC CODE" (NEC)/"AMERICAN NATIONAL STANDARDS INSTITUTE" (ANSI)/"NATIONAL FIRE PROTECTION ASSOCIATION" (NFPA) 70 AND LOCAL/STATE CODES. IN CANADA, ELECTRICAL GROUNDING IS TO BE IN ACCORDANCE WITH THE CANADIAN ELECTRIC CODE CSA C22.1. FAILURE TO OBSERVE THIS WARNING CAN RESULT IN ELECTRICAL SHOCK THAT CAN CAUSE PERSONAL INJURY.

WARNING

BEFORE SERVICING OR INSTALLING THIS EQUIPMENT, THE ELECTRICAL POWER TO THIS UNIT **MUST** BE IN THE "OFF" POSITION. CAUTION, MORE THAN ONE DISCONNECT MAY EXIST. FAILURE TO OBSERVE THIS WARNING MAY RESULT IN AN ELECTRICAL SHOCK THAT CAN CAUSE PERSONAL INJURY.

WARNING

DUE TO HIGH SYSTEM PRESSURE AND ELECTRICAL SHOCK POTENTIAL, INSTALLING AND THE SERVICING AIR CONDITIONING SYSTEMS CAN BE HAZARDOUS. ONLY TRAINED AND QUALIFIED PERSONNEL ARE PERMITTED TO INSTALL OR SERVICE THIS EQUIPMENT. OBSERVE ALL WARNINGS CONTAINED IN THIS MANUAL AND LABELS/TAGS ATTACHED TO THE EQUIPMENT.



WARNING

THIS PRODUCT IS FACTORY SHIPPED FOR USE WITH A 208-230/1/60 ELECTRICAL POWER SUPPLY. THIS AIR HANDLER **MUST NOT** BE RECONFIGURED TO OPERATE WITH ANY OTHER POWER SUPPLY.



WARNING

WHEN INSTALLING OR SERVICING THIS EQUIPMENT, SAFETY CLOTHING, INCLUDING HAND AND EYE PROTECTION, IS STRONGLY ADVISED. IF INSTALLING THIS EQUIPMENT IN AN AREA THAT HAS SPECIAL SAFETY REQUIREMENTS (HARD HATS ETC.), OBSERVE THESE REQUIREMENTS. TO PROTECT THE UNIT WHEN WELDING CLOSE TO THE PAINTED SURFACES, THE USE OF A QUENCHING CLOTH IS STRONGLY ADVISED TO PREVENT SCORCHING OR MARRING OF THE EQUIPMENT FINISH.



WARNING

THE UNITED STATES ENVIRONMENTAL PROTECTION AGENCY ("EPA") HAS ISSUED VARIOUS REGULATIONS REGARDING THE INTRODUCTION AND DISPOSAL OF REFRIGERANTS INTRODUCED INTO THIS UNIT. FAILURE TO FOLLOW THESE REGULATIONS MAY HARM THE ENVIRONMENT AND CAN LEAD TO THE IMPOSITION OF SUBSTANTIAL FINES. THESE REGULATIONS MAY VARY DUE TO THE PASSAGE OF LAWS. A CERTIFIED TECHNICIAN MUST PERFORM THE INSTALLATION AND SERVICE OF THIS PRODUCT. SHOULD QUESTIONS ARISE, CONTACT YOUR LOCAL EPA OFFICE.

MODEL IDENTIFICATION

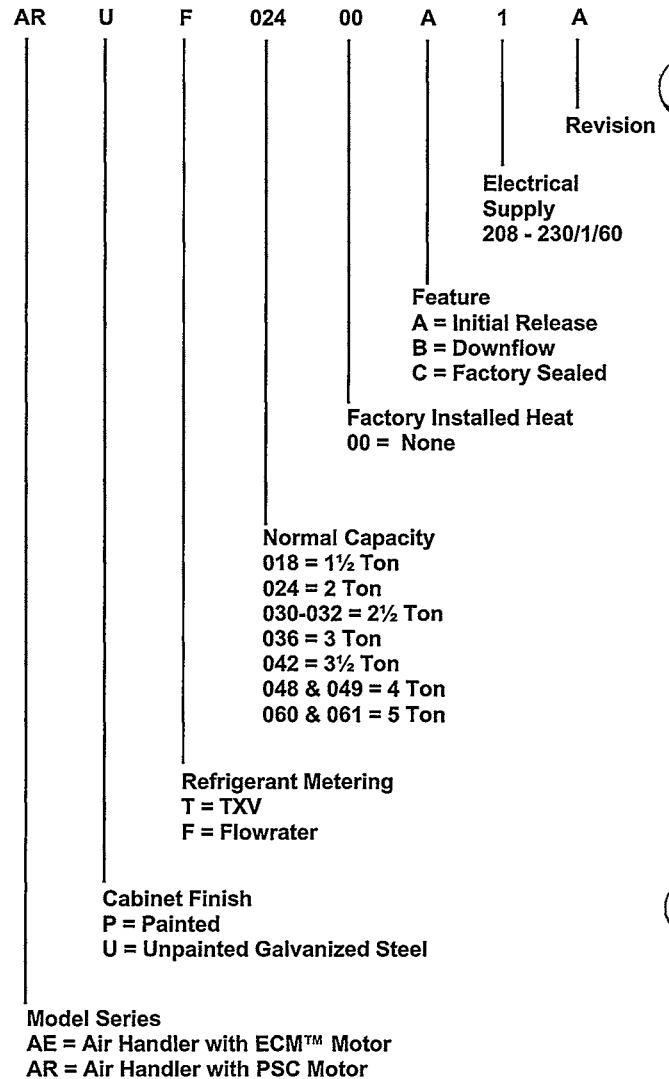

DANGER
PELIGRO

CARBON MONOXIDE POISONING HAZARD

Special Warning for Installation of Furnace or Air Handling Units in Enclosed Areas such as Garages, Utility Rooms or Parking Areas

Carbon monoxide producing devices (such as an automobile, space heater, gas water heater, etc.) should not be operated in enclosed areas such as unventilated garages, utility rooms or parking areas because of the danger of carbon monoxide (CO) poisoning resulting from the exhaust emissions. If a furnace or air handler is installed in an enclosed area such as a garage, utility room or parking area and a carbon monoxide producing device is operated therein, there must be adequate, direct outside ventilation.

This ventilation is necessary to avoid the danger of CO poisoning which can occur if a carbon monoxide producing device continues to operate in the enclosed area. Carbon monoxide emissions can be (re)circulated throughout the structure if the furnace or air handler is operating in any mode.

CO can cause serious illness including permanent brain damage or death.

B10259-216

PRODUCT DESCRIPTION

With the exception of the ARPF024-00B-1, ARPF036-00B-1, ARPF048-00B-1 and the ARPF060-00B-1 (referred to in this manual as the "B" series), these air handlers are designed to be installed in the upflow, downflow, and horizontal orientations.

The "B" series air handlers are factory configured to be installed in the downflow orientation. **DO NOT INSTALL THE "B" SERIES IN THE UPFLOW OR HORIZONTAL POSITION.**

The "C" series airhandler is designed for low leak applications. These air handlers are designed for indoor use only and must only be installed in a weatherized area. **DO NOT INSTALL OUTDOORS.** Typical residential installations for this product include alcoves, basements, attics, crawl spaces, and closets. Other nonresidential applications are acceptable provided they comply with this manual and local/state codes.

When matched with a Goodman or Amana brand condenser or heat pump, an ARI certified rating is available for many combinations.

The AEPT models are equipped with an ECM™ motor. An ECM™ motor is more efficient than a standard PSC motor and offers features such as soft-start, controlled off-delays, and constant CFM. Additional features and the associated controls are discussed later in this manual.

Electric heat is available for all models. This is an accessory and is not provided with the equipment. Use only the electric heat kits identified in the "Electric Heat" section of this manual.

These air handlers are intended for use with a room thermostat. This thermostat is not supplied with this equipment. Only thermostats that use 24 VAC operating voltage can be used.

UNIT INSPECTION

Upon delivery, inspect the unit for damage. Any damage must be reported immediately to the carrier. Do not install this equipment if it is determined that the integrity or safety has been compromised by freight damage.

Using the table "Model Identification" section, check the equipment model number to ensure the unit is appropriately sized for the condenser unit.

If an incorrect unit is supplied, it must not be installed and it is to be returned to the supplier. The manufacturer assumes no responsibility for the installation of incorrectly delivered units.

The evaporator coil contains a high-pressure inert gas holding charge.

ELECTRIC HEAT



WARNING

REFER TO THE "INSTALLING ELECTRIC HEAT" SECTION OF THIS MANUAL AND THE INSTRUCTIONS PROVIDED WITH THE HEAT KIT FOR THE CORRECT INSTALLATION PROCEDURE.



WARNING

THE ELECTRICAL CHARACTERISTICS OF THE AIR HANDLER, THE ELECTRIC HEAT KIT, AND THE SUPPLY POWER MUST AGREE, UNLESS USING HKR3 (3 PHASE) SERIES HEAT KIT. THIS AIR HANDLER DOES NOT HAVE FACTORY INSTALLED ELECTRIC HEAT. ELECTRIC HEAT IS AVAILABLE AS AN ACCESSORY. IF INSTALLING THIS OPTION, THE ONLY HEAT KITS THAT CAN BE USED ARE THE HKR SERIES AS INDICATED BELOW: NOTE: THE AMANA BRAND EHK, ECB, EDB, AND EDK KITS ARE NOT APPROVED FOR USE WITH THESE AIR HANDLERS.

The heating mode temperature rise is dependent upon the system airflow, the supply voltage, and the heat kit size (kW) selected. Use Tables 1-3 to determine the temperature rise (°F).

CFM	HEAT KIT NOMINAL kW							
	3	5	6	8	10	15	20	21
600	18	28	35	41				
800	13	21	26	31	42			
1000	11	17	21	25	34	50		
1200	9	14	18	21	28	42	56	62
1400	8	12	15	18	24	36	48	53
1600	7	10	13	15	21	31	42	46
1800	6	9	12	14	19	28	37	41
2000	5	8	11	12	17	25	34	37

Table 1

230/1/60 Supply Voltage - Temperature Rise Table °F

CFM	HEAT KIT NOMINAL kW							
	3	5	6	8	10	15	20	21
600	17	27	34	39				
800	13	20	25	30	40			
1000	10	16	20	24	32	48		
1200	8	13	17	20	27	40	53	59
1400	7	11	14	17	23	34	46	51
1600	6	10	13	15	20	30	40	44
1800	6	9	11	13	18	27	36	39
2000	5	8	10	12	16	24	32	35

Table 2

220/1/60 Supply Voltage - Temperature Rise Table °F

CFM	HEAT KIT NOMINAL kW							
	3	5	6	8	10	15	20	21
600	16	25	32	37				
800	12	19	24	38	38			
1000	10	15	19	22	30	46		
1200	8	13	16	19	25	38	51	56
1400	7	11	14	16	22	33	43	48
1600	6	9	12	14	19	28	38	42
1800	5	8	11	12	17	25	34	37
2000	5	8	10	11	15	23	30	34

Table 3

208/1/60 Supply Voltage - Temperature Rise Table °F

Note: For installations not indicated above the following formula is to be used:

$$TR = (kW \times 3412) \times (\text{Voltage Correction}) \times 1.08 / CFM$$

Where: TR = Temperature Rise
 KW = Heater Kit Actual kW
 3412 = Btu per kW

Voltage Correction = .96 (230 Supply Volts)
 = .92 (220 Supply Volts)
 = .87 (208 Supply Volts)

1.08 = Constant
 CFM = Measured Airflow

NOTE: The Temperature Rise Tables can also be used to determine the air handler airflow delivery. When using these tables for this purpose set the room thermostat to

maximum heat and allow the system to reach steady state conditions. Insert two thermometers, one in the return air and one in the supply air. The temperature rise is the supply air temperature minus the room air temperature.

Use HKR specification sheets to determine the HKR available for a given air handler.

HKR INSTALLATION

Follow instructions listed in Installation and Operating Instructions shipped with the heat kit.

LOCATION

WARNING

THIS AIR HANDLER IS DESIGNED FOR INDOOR INSTALLATION ONLY. DO NOT INSTALL OUTDOORS.

When installing this air handler consideration to minimize the length of refrigerant tubing is to be given. Do not install the air handler in a location either above or below the condenser that violates the instructions provided with the condenser. The clearance from a combustible surface to the unit is 0". However, service clearance is to take precedence. Allow a minimum of 24" in front of the unit for service clearance. When installing in an area directly over a finished ceiling (such as an attic), an emergency drain pan is required directly under the unit. See local and state codes for additional requirements. When installing this unit in an area that may become wet, elevate the unit with a sturdy, non-porous material. In installations that may lead to physical damage (i.e. a garage) it is advised to install a protective barrier to prevent such damage.

DUCTWORK

This air handler is designed for a complete supply and return ductwork system.

CAUTION

DO NOT OPERATE THIS PRODUCT WITHOUT ALL DUCTWORK ATTACHED.

To ensure correct system performance, the ductwork is to be sized to accommodate 375-425 CFM per ton of cooling with the static pressure not to exceed .5" WC. Inadequate ductwork that restricts airflow can result in improper performance and compressor or heater failure. Ductwork is to be constructed in a manner that limits restrictions and maintains suitable air velocity. Ductwork is to be sealed to the unit in a manner that will prevent leakage.

Return Ductwork. DO NOT TERMINATE THE RETURN DUCTWORK IN AN AREA THAT CAN INTRODUCE TOXIC, OR OBJECTIONABLE FUMES/ODORS INTO THE DUCTWORK. The return ductwork is to be introduced into the air handler bottom (upflow configuration).

Return Air Filters. Each installation must include a return air filter. This filtering may be performed at the air handler or externally such as a return air filter grille. Air handlers mounted in the downflow orientation, including "B" series,

require external filtering. A washable filter is available as an accessory. To ensure optimum performance frequent filter cleaning is advised. Refer to Table 5 for the appropriate filter.

ARUFor ARPT model	ARPF model	AEPT model	Filter Number	Qty Required
018-032	024, 036	n/a	FIL 18-32	1
036-042	n/a	30	FIL 36-42	1
048-061	048, 060	036, 060	FIL 48-61	1

Table 5

ELECTRICAL SUPPLY WIRE AND MOP

WARNING

TO AVOID THE RISK OF FIRE OR EQUIPMENT DAMAGE, USE ONLY COPPER CONDUCTORS. BEFORE SERVICING OR INSTALLING THIS EQUIPMENT, THE ELECTRICAL POWER TO THIS UNIT **MUST** BE IN THE "OFF" POSITION AND ALL POWER SUPPLIES DISCONNECTED.

CAUTION

MORE THAN ONE DISCONNECT MAY EXIST. FAILURE TO OBSERVE THIS WARNING MAY RESULT IN AN ELECTRICAL SHOCK THAT CAN CAUSE PERSONAL INJURY OR DEATH.

WARNING

THE UNIT **MUST** HAVE AN UNINTERRUPTED, UNBROKEN ELECTRICAL GROUND TO MINIMIZE THE POSSIBILITY OF PERSONAL INJURY IF AN ELECTRICAL FAULT SHOULD OCCUR. THE ELECTRICAL GROUND CIRCUIT MAY CONSIST OF AN APPROPRIATELY SIZED ELECTRICAL WIRE CONNECTING THE GROUND LUG IN THE UNIT AND CONTROL BOX WIRE TO THE BUILDING'S ELECTRICAL SERVICE PANEL. OTHER METHODS OF GROUNDING ARE PERMITTED IF PERFORMED IN ACCORDANCE WITH THE "NATIONAL ELECTRIC CODE" (NEC)/"AMERICAN NATIONAL STANDARDS INSTITUTE" (ANSI)/"NATIONAL FIRE PROTECTION ASSOCIATION" (NFPA) 70 AND LOCAL/STATE CODES. IN CANADA, ELECTRICAL GROUNDING IS TO BE IN ACCORDANCE WITH THE CANADIAN ELECTRIC CODE CSA C22.1. FAILURE TO OBSERVE THIS WARNING CAN RESULT IN ELECTRICAL SHOCK THAT CAN CAUSE PERSONAL INJURY OR DEATH.

Inspection of the Building Electrical Service

This unit is designed for single-phase electrical supply. DO NOT OPERATE ON A THREE-PHASE POWER SUPPLY. Measure the power supply to the unit. The supply voltage **must** be in agreement with the unit nameplate power requirements and within the range shown in Table 6.

Nominal Input	Minimum Voltage	Maximum Voltage
208/230	187	253

Table 6

Wire Sizing

Wire size is important to the operation of your equipment. Use the following check list when selecting the appropriate wire size for your unit.

- **Wire size must carry the Minimum Circuit Ampacity (MCA).**

Refer to the NEC (USA) or CSA (Canada) for wire sizing. The unit MCA for the air handler and the optional electric heat kit can be found on the unit Series and Rating Plate.

- **Wire size allows for no more than a 2% voltage drop from the building breaker/fuse panel to the unit.**

Refer to the latest edition of the National Electric Code or in Canada the Canadian Electric Code when determining the correct wire size. The following table shows the current carrying capabilities for copper conductors rated at 75°C with a 2% voltage drop. Use the **Table 7** to determine the voltage drop per foot of various conductors.

Maximum Allowable Length in Feet to Limit Voltage Drop to 2%*								
Wire Size (AWG)	Minimum Circuit Ampacity (MCA)							
	10	15	20	25	30	35	40	45
14	75	50	37	NR	NR	NR	NR	NR
12	118	79	59	47	NR	NR	NR	NR
10	188	125	95	75	63	54	NR	NR
8	301	201	150	120	100	86	75	68
6	471	314	235	188	157	134	118	110

*Based on NEC 1996

Table 7

Maximum Overcurrent Protection (MOP)

Every installation must include an NEC (USA) or CEC (Canada) approved overcurrent protection device. Also, check with local or state codes for any special regional requirements.

This protection can be in the form of fusing or HACR style circuit breakers. The Series and Rating Plate can be used as a guide for selecting the MAXIMUM overcurrent device.

NOTE: Fuses or circuit breakers are to be sized larger than the equipment MCA but not to exceed the MOP.

Electrical Connections – Supply Voltage USE COPPER CONDUCTORS ONLY.

A knockout is provided on the air handler top panel or side to allow for the entry of the supply voltage conductors. If the knockouts on the cabinet sides are used for electrical conduit, an adapter ring must be used in order to meet UL1995 safety requirements. An NEC or CEC approved strain-relief is to be used at this entry point. The wire is to be sized in accordance with the "Electrical Wire and MOP" section of this manual. Some areas require the supply wire to be enclosed in conduit. Consult your local codes.

Air Handler Only (Non-Heat Kit Models)

The building supply connects to the stripped black and white wires contained in the air handler electrical compartment cavity. A ground screw is also contained in this area. Attach the supply wires to the air handler conductors as shown in the unit wiring diagram using appropriately sized solderless connectors or other NEC or CEC approved means.

Air Handler With Non-Circuit Breaker Heat Kits

A terminal block is provided with the HKR kit to attach the supply and air handler connections. Follow the HKR Installation Manual and wiring diagram for complete wiring details.

Air Handler With Heat Kits Containing a Circuit Breaker.

HKR models with a "C" suffix contain a circuit breaker(s). The air handler has a plastic cover on the access panel that will require either one or both sections to be removed to allow the heat kit circuit breaker(s) to be installed. See the HKR Installation Instructions for further details. The air handler wires and supply wires are installed directly onto the HKR circuit breaker(s) as shown in the HKR Installation Manual and wiring diagram.

Low Voltage Connections

Several combinations of low voltage schemes are available, depending on the presence of a heat kit and whether the heat kit is single-stage or multi-staging. The low voltage connections are determined by whether the outdoor unit is a condenser or heat pump. The 24V-control voltage connects the air handler to the room thermostat and condenser. Low voltage wiring is to be copper conductors. A minimum of 18AWG must be used for installations up to 50' and 16AWG for installations over 50'. Low voltage wiring can be made through the top of the cabinet or through either side. See the "Thermostat Wiring" section of this manual for the ARUF, ARPF and ARPT models for typical low voltage wiring connections. The Supplemental Installation Manual included with the AEPT product shows the wiring diagrams for these models.

REFRIGERANT LINES

WARNING

TO PROTECT THE UNIT WHEN WELDING CLOSE TO THE PAINTED SURFACES, THE USE OF A QUENCHING CLOTH IS STRONGLY ADVISED TO PREVENT SCORCHING OR MARRING OF THE EQUIPMENT FINISH. SOLDER WITH A MINIMUM OF 5% SILVER IS RECOMMENDED.

Tubing Preparation

All cut ends are to be round, burr free, and cleaned. Failure to follow this practice increases the chances for refrigerant leaks. The suction line is spun closed and requires pipe cutters to cut off the closed end.

Post Brazing

Quench all welded joints with water or a wet rag.

Piping Size

For the correct tubing size, follow the specification for the condenser/heat pump.



WARNING

THIS COIL IS SHIPPED UNDER PRESSURE. FOLLOW THESE INSTRUCTIONS TO PREVENT INJURY (SEE FIGURES 1 AND 2).

Evaporator Coil Metering Devices

Flowrater Models (ARUF and ARPF)

For most installations no change to the flowrater orifice is required. In mix-matched applications (condenser/heat pump is a different tonnage than the air handler), a different flowrater orifice may be required. See the Goodman piston kit chart PKC-00 or latest revision. Consult your local distributor for the details regarding mix-matched orifice sizing.

1. Loosen the 13/16 nut **1 TURN ONLY**. No pressure loss indicates possible leak.
2. Remove the nut and discard the black or brass cap.
3. Remove the check piston to **verify it is correct**. See piston kit chart in instructions.
4. Use a tube cutter to remove the spin closure on the suction line.
5. Remove the tailpiece clamped to the exterior.
6. **Slide the 13/16 nut into position**. Braze tailpiece to the liquid tube.
7. Insert the suction line into the connection, slide the insulation and the rubber grommet at least 18" away from the braze joint.
8. **AFTER THE TAILPIECE HAS COOLED**, position the white Teflon seal and hand tighten the nut.
9. Torque the 13/16 nut to 20-30 ft-lbs. [2.77-4.15 meter kg].
10. Replace suction line grommet and insulation.

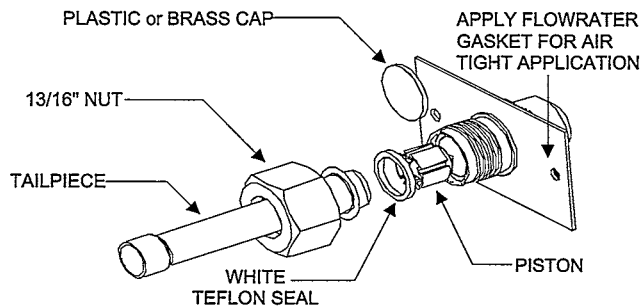

Figure 1

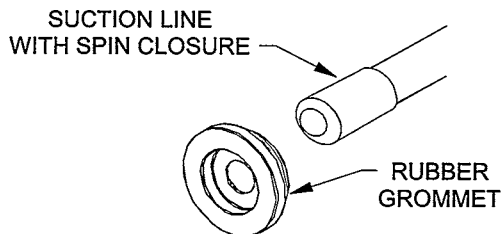

Figure 2

TXV Models (ARPT and AEPT)

IMPORTANT NOTE: In order to prevent damage to the sensing bulb, it is not permanently installed in the factory. This bulb is to be removed prior to brazing. Place in proper location after braze joint has cooled (Figure 3).

1. Loosen the 13/16 nut **1 TURN ONLY**. No pressure loss indicates possible leak.
2. Remove the nut and discard the black or brass cap.
3. Remove large front panel and remove sensing bulb from suction manifold. **TO PREVENT DAMAGE TO SENSING BULB, ENSURE BULB IS NOT NEAR FLAME OR IN CONTACT WITH SUCTION LINE OR MANIFOLD DURING BRAZING.**
4. Use a tube cutter to remove the spin closure on the suction line.
5. Remove the tailpiece clamped to the exterior.
6. **Slide the 13/16 nut into position (Figure 1)**. Braze tailpiece to liquid tube.
7. Insert the suction line into the connection, slide the insulation and the rubber grommet at least 18" away from the braze joint.
8. **AFTER THE TAILPIECE HAS COOLED**, position the white Teflon seal and hand tighten the nut.
9. Torque the 13/16 nut to 20-30 ft-lbs. [2.77-4.15 meter kg].
10. Replace sensing bulb to horizontal portion of suction line (Figure 3) just inside cabinet. Place bulb parallel with suction line in the 10 o'clock position. If 10 o'clock position is inaccessible, place in the 2 o'clock position. Secure bulb to line with strapping provided in literature envelope. Insulate sensing bulb to line with self-adhesive insulation provided in envelope.
11. Replace access panel, suction line grommet, and insulation.

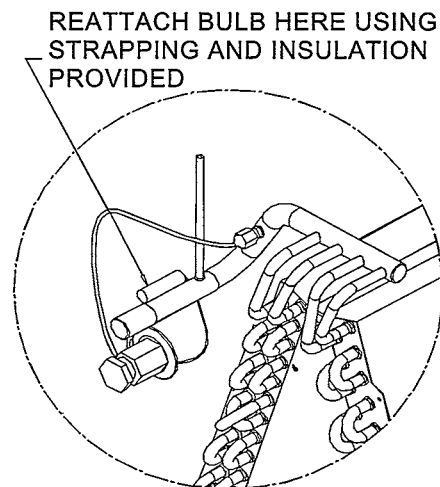

Figure 3

For the majority of installations, no adjustment to the TXV setting is required. However, if the measured superheat is less than 8° or greater than 20°, an adjustment is required. The adjustment stem is at the base of the valve (opposite the diaphragm) under the flare nut.

To increase the superheat (measured at the condenser base valve), turn the stem clockwise (in). Similarly, to decrease the superheat, turn the stem counterclockwise (out). Use a ¼" refrigeration wrench for this function.

Note: Design point for the system is 10 degrees of superheat (measured at the condenser base valve) at 95 degree outdoor air.

Charging Note: Air handlers with TXV's (ARPT's and AEPT's) should be charged to 15 degrees of subcooling at the indoor inlet. This supercedes any subcooling value listed with condensing unit's literature.

AEPT MOTOR ORIENTATION

If the unit is in the upflow position, there is no need to rotate the motor. If the unit is in the downflow or horizontal position, loosen motor mount and rotate motor as shown in Figure 4. Be sure motor is oriented with the female connections on the casing pointing down. If the motor is not oriented with the connections pointing down, water will collect in the motor and cause premature failure.

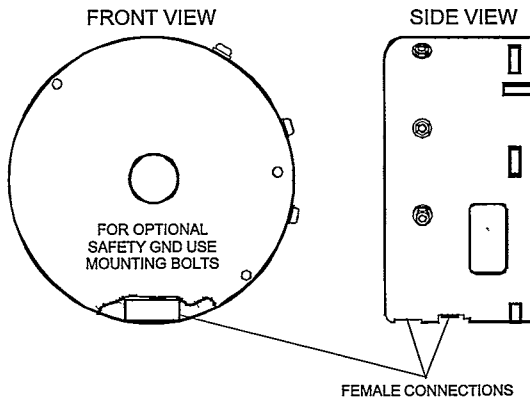

Figure 4
AEPT Motor Orientation

CONVERSION TO DOWNFLOW

The ARPF "B" series product is factory equipped for downflow operation and no field conversion is required. It is recommended that the conversion to downflow be performed before placing the air handler in its final location and in an area that allows for access to all sides. To prevent the evaporator coil pan from "sweating" the DPI accessory insulation kit is to be used when performing this conversion. Note: The DPI kit is not supplied with this product and is to be purchased separately. See Table 8 for the correct DPI kit.

ARUFor ARPT model	AEPT model	Insulation Kit
018-032	n/a	DPI18-30/20
036-042	30	DPI36-42/20
048-061	036, 060	DPI48-61/20

Table 8

Refer to **Figures 5 through 7** for the location of the components referenced in the following steps. **Figure 5** illustrates the new installation location for the removed components.

1. Before inverting the air handler, remove all access panels, the coil rear channel bracket, and the filter close-off panel.
2. Remove the evaporator coil and the horizontal drain pan. Discard horizontal drain pan.
3. Install the provided plastic plug into the vacated access panel.
4. Remove the two (2) zee coil support brackets and insulation retaining brackets.
5. Remove the tie bracket.
6. Install the DPI Insulation Kit onto the bottom of the drain pan.

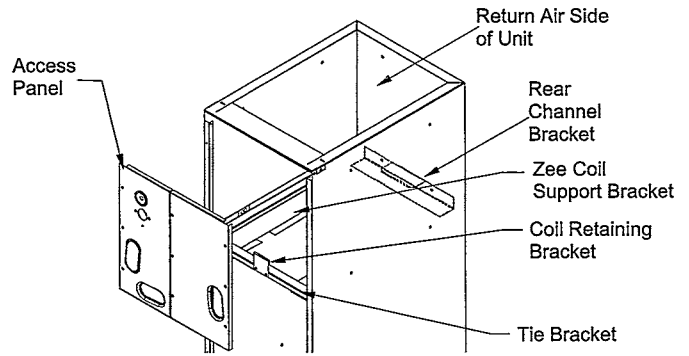

NOTE: The filter provision is not applicable in THIS downflow application.

Figure 5

7. Install the zee coil supports and the wrapper stiffeners.
8. Install the tie bracket.
9. Install the rear channel bracket.
10. To prevent possible condensate "blow off" the insulation retainers are to be laid into the evaporator coil pan as shown in **Figure 6**.

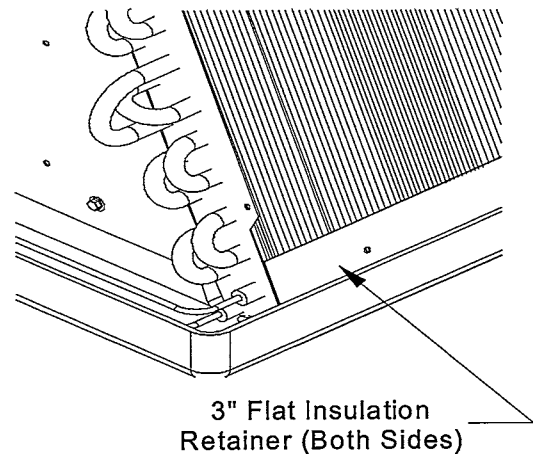

Figure 6

To complete the conversion, slide the evaporator coil into the chassis and attach the three access panels. (Figure 7).

CONVERSION TO HORIZONTAL

The "B" series product is not suitable for horizontal application and must not be used for this type of installation. The following describes converting to "Horizontal Left-Hand". The only field modification required for conversion to "Horizontal Right-Hand" is the removal of the plastic knockouts in the horizontal panel drain connections.

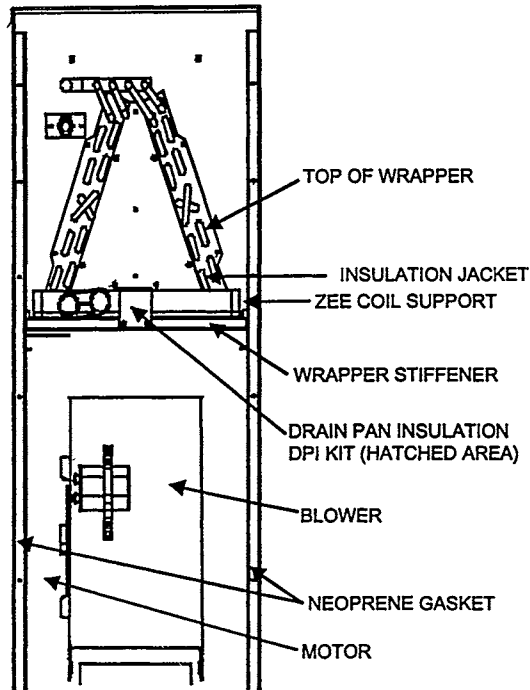

Figure 7

As shown in Figure 8, it is recommended that the conversion to horizontal be performed before placing the air handler in its final location and in an area that allows for access to all sides.

1. Remove the (3) air handler access panels.
2. Remove the "J" shaped bracket that retains the evaporator coil.
3. Remove the flowrater (or TXV) from the lower left side access panel and slide out the evaporator coil and horizontal drain pan.
4. Remove the gasket from the horizontal pan drain connections.
5. Remove the oval shaped plastic plug from the left side access panel. Remove the oval shaped rubber gasket seal from the lower right side access panel.
6. The drain connections for the horizontal pan are sealed with a thin coating of plastic. Carefully knock out this plastic seal with a screwdriver and hammer. **Note: The upper drain will become the secondary drain which is mandatory in many municipalities .**

7. Install the plastic plug removed in step 5 to the right side lower access panel and the oval shaped rubber gasket to the lower left access panel.
8. Reinstall the evaporator coil with the horizontal panel on the left side. Note: Push the assembly completely to the rear to ensure the engagement of the upflow pan with the rear channel bracket.
9. Install the "J" bracket (removed in step 2) to support the upflow pan to the tie channel.
10. Attach all panels and the refrigerant management device.

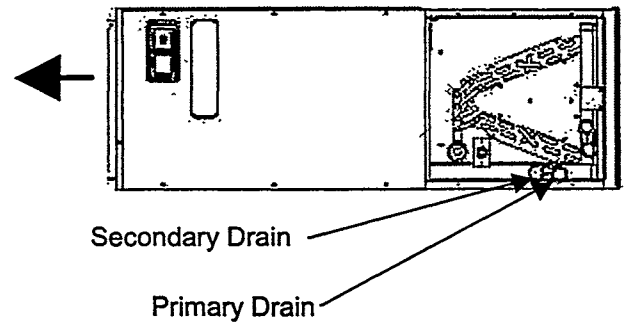

Figure 8

CONDENSATE REMOVAL

The drain pan has a primary and secondary drain connection (Figure 8). Condensate removal is performed by attaching a 3/4" PVC pipe to the evaporator coil pan and terminated in accordance with local or state Plumbing/HVAC codes. The installation must include a "P" style trap that is located as close as is practical to the evaporator coil. Exercise caution not to over-tighten the drain connection(s) in order to prevent possible damage to the evaporator drain pan. See Figure 9 for details of a typical condensate line "P" trap.

Installations that are above a finished ceiling may require a field supplied auxiliary drain pan. Consult local codes on this requirement.

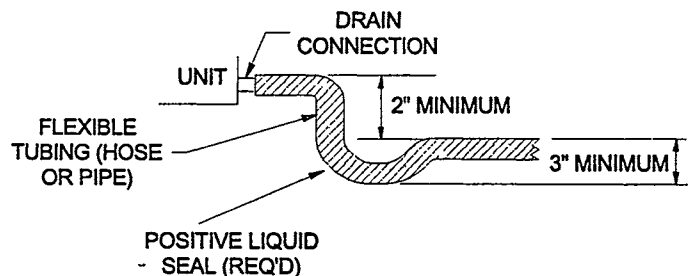

Figure 9

Use of a condensate removal pump is permitted when necessary. This condensate pump should have provisions for shutting off the control voltage should a blocked drain occur. A trap must be installed between the unit and the condensate pump.

IMPORTANT NOTE: THE EVAPORATOR COIL IS COATED WITH OILS THAT MAY DISSOLVE STYROFOAM AND CERTAIN TYPES OF PLASTICS. THEREFORE, A REMOVAL PUMP OR FLOAT SWITCH MUST NOT CONTAIN ANY OF THESE MATERIALS.

Tip: Priming the "P" trap may avoid improper draining at the initial installation and at the beginning of the cooling season.

ACHIEVING 2% LOW LEAKAGE RATE

Ensure that the Neoprene gasket with PSA remains intact on all surfaces that the access panels are secured to. These surfaces are the entire length of the wrapper and areas between the upper tie plate, upper and lower access panels. Be sure that upper access panel breaker insert gasket is intact and also flowrator gasket is installed on the lower access panel. An additional drain hole cover is required.

ARUF/ARPF MOTOR

Motor Speed Adjustment

The motors in all ARUF and ARPF motors are multi-speed PSC motors. The color of the wire coming from the motor to the "COM" terminal on the control board defines in which speed the motor will operate. The black wire represents high speed, the red wire represents low speed, and the blue wire (select models only) represents medium speed. To change speeds, remove the wire attached to the "COM" terminal on the control board, and swap it with the wire (on terminal "M1" or "M2") with the color that will give the desired speed.

NOTE: In some models, not all speed taps are allowable for certain electric heat applications. Refer to air handler Series and Ratings plate for minimum speed.

AEPT MOTOR

This section references the operation characteristics of the AEPT model motor only. The ECM control board is factory set with dipswitch #4 in the "ON" position and all other dipswitches in the "OFF" position. ***For most applications this setting is to be changed according to the electric heat size and the outdoor unit selection.***

The AEPT product uses a General Electric ECM™ motor. This motor provides many features not available on the traditional PSC motor. These features include:

- Improved Efficiency
- Constant CFM
- Soft Start and Stop
- Improved Humidity Control

Motor Speed Adjustment

Each ECM™ blower motor has been preprogrammed for operation at 4 distinct airflow levels when operating in Cooling, H.P. Heating, Backup Heating (Electric Heating), and Backup + H.P. Heating. Each mode has 4 levels to deliver different Air Flow CFM [L/s]. The adjustment is performed by changing the dipswitch(s) either to an "OFF" or "ON" position.

Dipswitch Functions

The AEPT air handler motor has an electronic control that contains an eight (8) position dip switch. The function of these dipswitches are shown in **Table 9**.

Dipswitch Number	Function
1	Electric Heat
2	
3	N/A
4	Indoor Thermostat
5	Cooling & Heat Pump CFM
6	
7	CFM Trim Adjust
8	

Table 9

CFM Delivery

Tables 10 and 11 show the CFM output for dipswitch combinations 1-2, and 5-6.

Model	Switch 1	Switch 2	EMERGENCY (ELECTRIC) HEAT	HP w/BACKUP HEAT
AEPT30	OFF	OFF	1100	1210
	ON	OFF	850	935
	OFF	ON	700	775
AEPT36 and AEPT60	OFF	OFF	2050	2150
	ON	OFF	1750	1835
	OFF	ON	1600	1680
	ON	ON	1200	1260

TABLE 10 - ELECTRIC HEAT CFM

Model	Switch 5	Switch 6	Nominal Cooling Tonnage	CFM
AEPT30	OFF	OFF	2 ½	1100
	ON	OFF	2	800
	OFF	ON	1 ½	600
AEPT36 and AEPT60	OFF	OFF	5	1800
	ON	OFF	4	1580
	OFF	ON	3 ½	1480
	ON	ON	3	1200

Table 11 - Cooling and Heat Pump CFM

Thermostat "Fan Only Mode"

During "Fan Only Mode" operation, the CFM output is 30% of the cooling setting.

CFM Trim Adjust

Minor adjustments can be made through the dip switch combination of 7-8. The following **Table 12** shows the switch position for this feature.

CFM	Switch 7	Switch 8
+10%	ON	OFF
-15%	OFF	ON

Table 12

Humidity Control

When using a Humidistat (normally closed), cut jumper PJ6 on the control board. The Humidistat will only affect cooling airflow by adjusting the Airflow to 85%.

Two Stage Heating

When using staged electric heat, cut jumper PJ4 on the control board.

Thermostat Wiring

Use thermostat wiring diagram **Figures 10 thru 13** and those provided with the thermostat when making these connections.

NOTE: DO NOT USE THESE DIAGRAMS FOR AEPT MODELS. SEE SUPPLEMENTAL INSTALLATION AND OPERATING INSTRUCTIONS FOR AEPT MODELS.

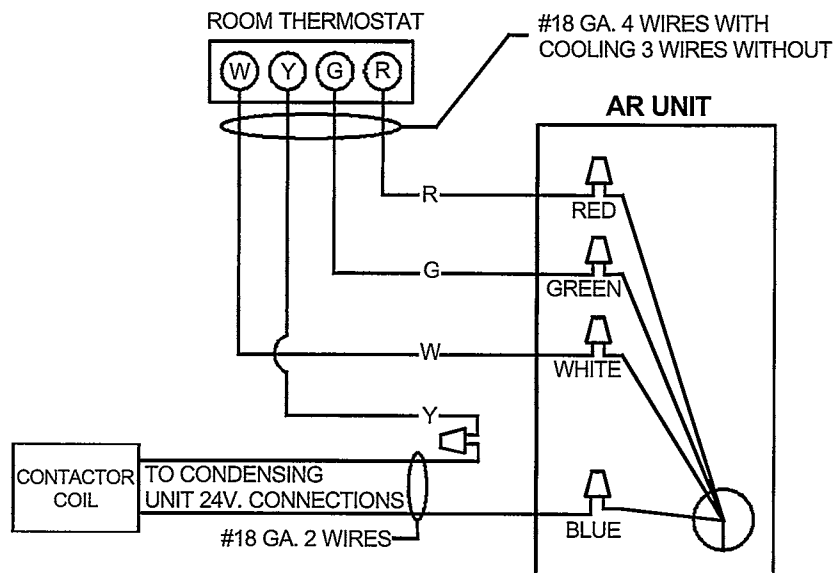

Figure 10 - Low Voltage Wiring Diagram for Cooling Unit with optional heat kit 10KW and below

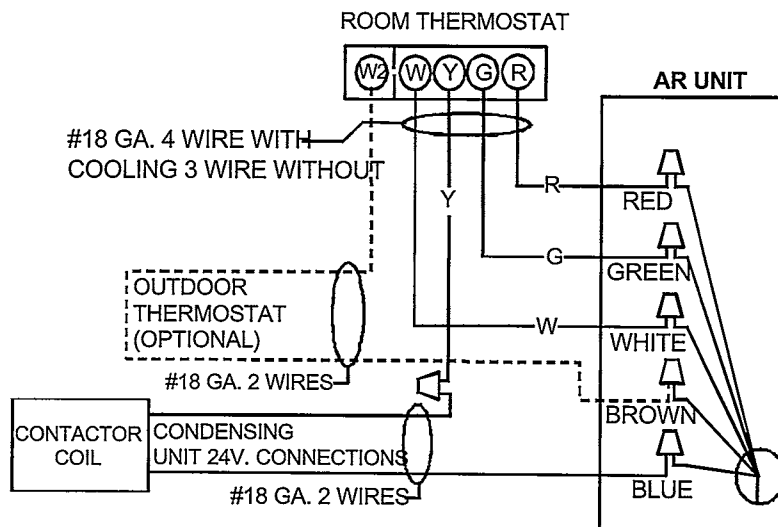
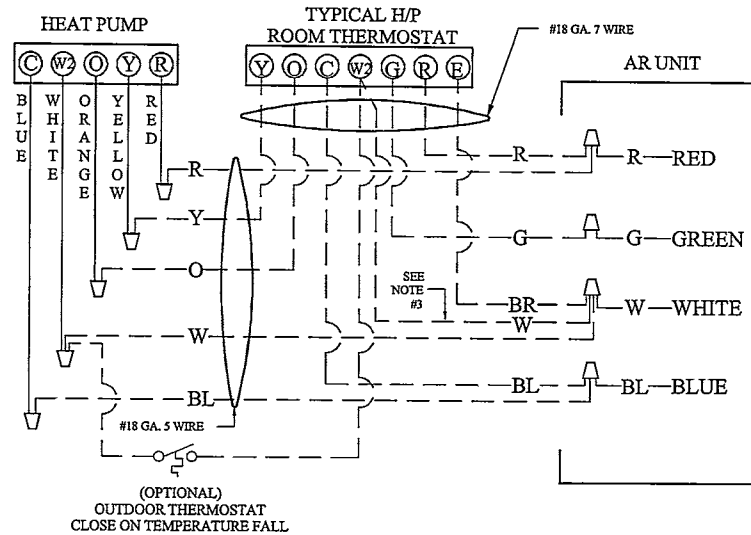

Figure 11 - Low Voltage Wiring Diagram for Cooling Unit with optional heat kit 15KW and above

AR/ARUF/ARPF/ARPT
18-60
10 KW & BELOW

FIGURE 12



#18 GA. 6 WIRE NEEDED WHEN OT IS USED

AR/ARUF/ARPF/ARPT
18-60
ABOVE 10 KW

FIGURE 13

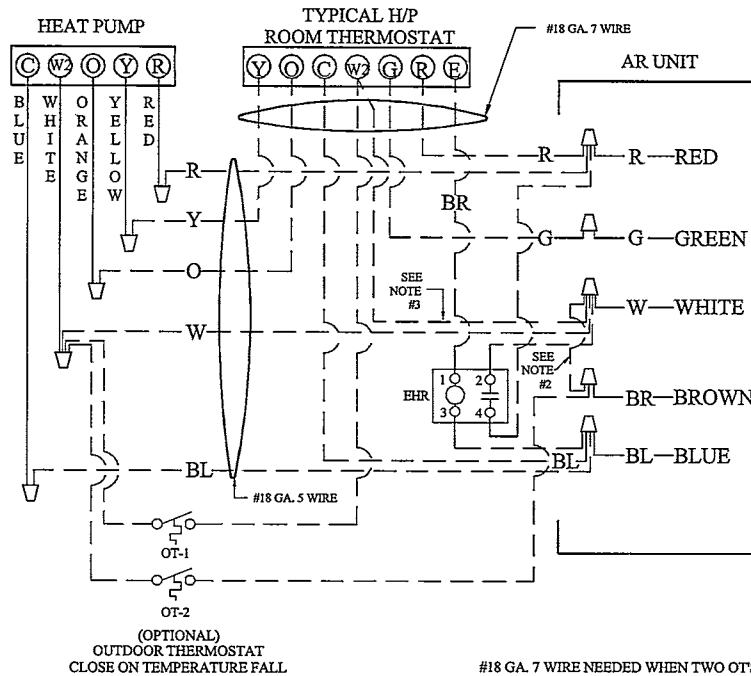

#18 GA. 7 WIRE NEEDED WHEN TWO OT'S ARE USED

NOTES:

- 1) OUTDOOR THERMOSTAT (OT-1) SHOULD BE THE FIRST TO CLOSE AND THE LAST TO OPEN.
- 2) CONNECT WHITE AND BROWN WIRES FROM AIR-HANDLER TOGETHER IF OT-2 IS NOT USED.
- 3) REMOVE WIRE WHEN USING OUTDOOR THERMOSTAT

NOMENCLATURE

- OT - OUTDOOR THERMOSTAT (OPTIONAL)
EHR - EMERGENCY HEAT RELAY (OPTIONAL)

COLOR CODES

- R - RED
Y - YELLOW
BL - BLUE
BR - BROWN
O - ORANGE
W - WHITE
G - GREEN

Important: If outdoor thermostat is not used, tie white and brown wires from Air Handler together

THERMOSTATS

Note: Second Stage heat can be accomplished by multi-stage heating thermostat or the addition of an outdoor thermostat as shown in Figures 12 and 13.

Goodman part number CHT18-60 is a single-stage cool and single-stage heat thermostat.

Goodman part number HPT18-60 is a single-stage cool, two-stage heat pump thermostat. The first stage is heat pump heating and the second stage is optional electric heat.

If additional features are desired, such as digital or programmable capabilities, these thermostats are commercially available. Follow the thermostat manufacturer's instruction for installation.

START-UP PROCEDURE

- Prior to start-up, ensure that all electrical connections are properly sized and tightened.
- All panels must be in place and secured. For Air Tight application, neoprene gasket must be positioned at prescribed locations to achieve 2% leakage.
- Tubing must be leak free.
- Unit should be elevated, trapped and pitched to allow for drainage.
- Low voltage wiring is connected.
- Auxiliary drain is installed when necessary and pitched to allow for drainage.

- Drain pan and drain tubing has been leak checked.
- Return and supply ducts are sealed.
- Unit is elevated when installed in a garage or where flammable vapors may be present.
- Unit is protected from vehicular or other physical damage.
- Return air is not obtained from any areas where there may be objectionable odors, flammable vapors or products of combustion such as carbon monoxide (CO), which may cause serious personal injury or death.

REGULAR MAINTENANCE



WARNING

DISCONNECT ALL POWER SUPPLIES BEFORE PERFORMING ANY SERVICE. NOTE THAT THERE MAY BE MORE THAN ONE POWER SUPPLY. FAILURE TO OBSERVE THIS WARNING CAN RESULT IN ELECTRICAL SHOCK THAT CAN CAUSE PERSONAL INJURY OR DEATH.

The only item to be maintained on a regular basis by the user is the circulating air filter(s). Filter should be cleaned or replaced regularly. A certified service technician must perform all other services.

Quality Makes the Difference!

All of our systems are designed and manufactured with the same high quality standards regardless of size or efficiency. We have designed these units to significantly reduce the most frequent causes of product failure. They are simple to service and forgiving to operate. We use quality materials and components. Finally, every unit is run tested before it leaves the factory. That's why we know. . . **There's No Better Quality.**

Visit our websites at www.goodmanmfg.com or www.amana-hac.com for information on:

- Products
- Warranties
- Customer Services
- Parts
- Contractor Programs and Training
- Financing Options

© 2003-2004 Goodman Manufacturing Company, L.P.